

# Real-Time Stream Monitoring

by Maximilian Schwenger



**amazon**

# amazon



⋮





⋮





⋮



 book review

>500  reviewed



⋮



# Pyhton?

 book review

>500  reviewed



*Lola!*

 book review

>500  reviewed



⋮



0 0 1 2 2 3 3 3 4 5 5 5

⋮

⊥ ⊥ ⊥ ⊥ ⊥ ⊥ ⊥ ⊥ ⊥ ⊥ ⊥ ⊥

 book review

>500  reviewed



# Lola

```
in stars, pid
```

```
out isBook :=  
  if pid =  then 1 else 0
```

```
out #books :=  
  #books [-1,0] + isBook [0,0]
```

```
trigger #books >= 5  
trigger badRev
```

>500  reviewed

# Lola

```
in stars, pid
```

```
out isBook :=  
  if pid =  then 1 else 0
```

```
out #books :=  
  #books [-1, 0] + isBook [0, 0]
```

   
offset default

```
trigger #books >= 5  
trigger badRev
```

>500  reviewed

# Lola

in stars, pid

```
out isBook :=  
  if pid =  then 1 else 0
```

```
out #books :=  
  #books [-1, 0] + isBook [0, 0]
```

 offset     default

```
trigger #books >= 5  
trigger badRev
```

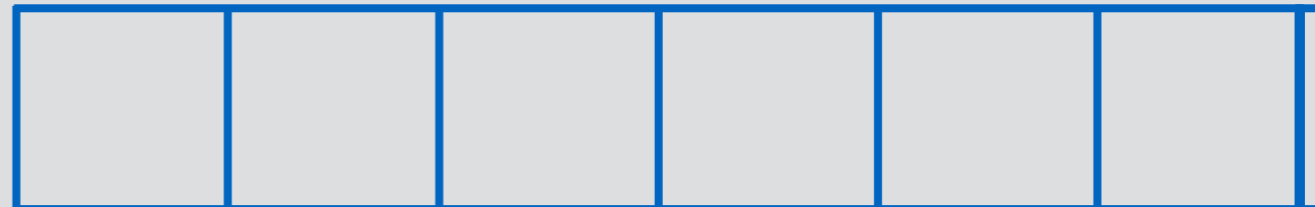
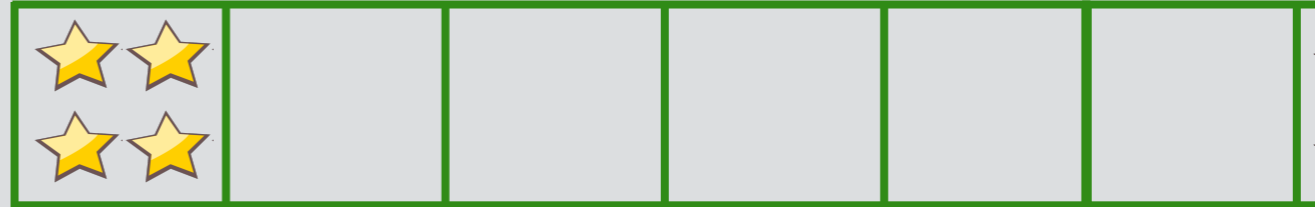

# Lola

in stars, pid

```
out isBook :=  
  if pid =  then 1 else 0
```

```
out #books :=  
  #books [-1, 0] + isBook [0, 0]
```

   
offset default

```
trigger #books >= 5  
trigger badRev
```

					
---	--	--	--	--	--

					
---	--	--	--	--	--

0					
---	--	--	--	--	--

--	--	--	--	--	--

# Lola

in stars, pid

```
out isBook :=  
  if pid =  then 1 else 0
```

```
out #books :=  
  #books [-1, 0] + isBook [0, 0]
```

↑ offset    ↑ default

```
trigger #books >= 5  
trigger badRev
```



# Lola

in stars, pid

```
out isBook :=  
  if pid =  then 1 else 0
```

```
out #books :=  
  #books [-1, 0] + isBook [0, 0]
```

↑ offset    ↑ default

```
trigger #books >= 5  
trigger badRev
```



# Lola

in stars, pid

```
out isBook :=  
  if pid =  then 1 else 0
```

```
out #books :=  
  #books [-1, 0] + isBook [0, 0]
```

   
offset default

```
trigger #books >= 5  
trigger badRev
```

					
---	---	--	--	--	--

0					
---	--	--	--	--	--

0					
---	--	--	--	--	--

# Lola

in stars, pid

```
out isBook :=  
  if pid =  then 1 else 0
```

```
out #books :=  
  #books [-1, 0] + isBook [0, 0]
```

   
offset default

```
trigger #books >= 5  
trigger badRev
```

					
---	---	--	--	--	--

0	1				
---	---	--	--	--	--

0					
---	--	--	--	--	--



# Lola

in stars, pid

```
out isBook :=  
  if pid =  then 1 else 0
```

```
out #books :=  
  #books [-1, 0] + isBook [0, 0]
```

 offset     default

```
trigger #books >= 5  
trigger badRev
```

					
---	---	--	--	--	--

0	1				
---	---	--	--	--	--

0	1				
---	---	--	--	--	--

# Lola

in stars, pid

```
out isBook :=  
  if pid =  then 1 else 0
```

```
out #books :=  
  #books [-1, 0] + isBook [0, 0]
```

 offset     default

```
trigger #books >= 5  
trigger badRev
```



# Lola

in stars, pid

```
out isBook :=  
  if pid =  then 1 else 0
```

```
out #books :=  
  #books [-1, 0] + isBook [0, 0]
```

 offset     default

```
trigger #books >= 5  
trigger badRev
```

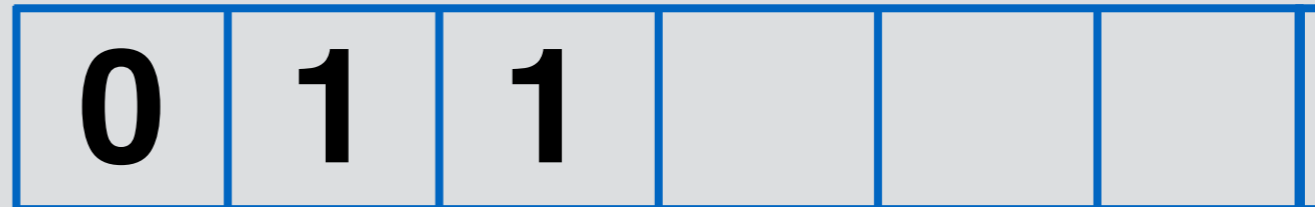

# Lola

in stars, pid

```
out isBook :=  
  if pid =  then 1 else 0
```

```
out #books :=  
  #books[-1, 0] + isBook[0, 0]
```

   
offset default

```
trigger #books >= 5  
trigger badRev
```

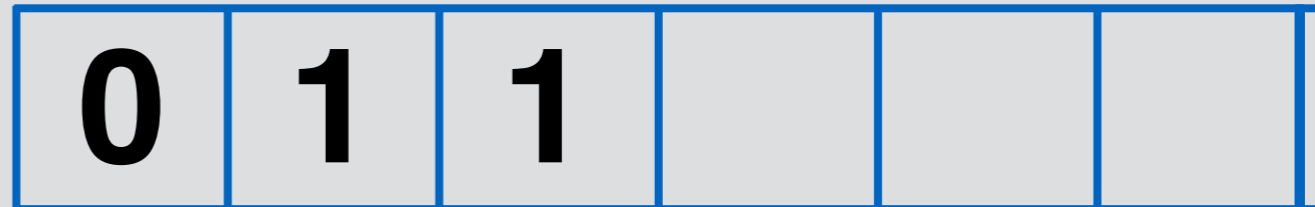

# Lola

in stars, pid

```
out isBook :=  
  if pid =  then 1 else 0
```

```
out #books :=  
  #books [-1, 0] + isBook [0, 0]
```

   
offset default

```
trigger #books >= 5  
trigger badRev
```

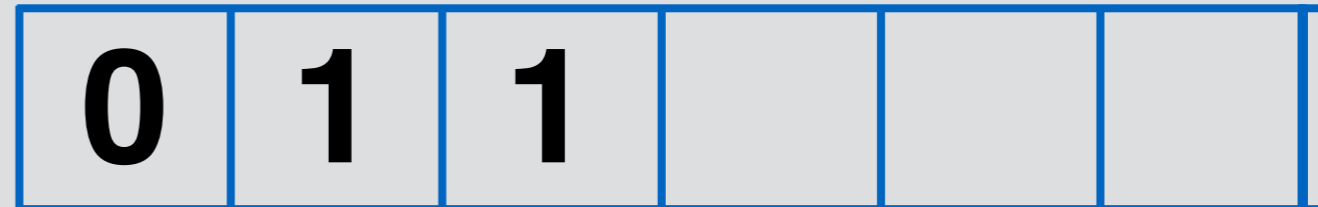
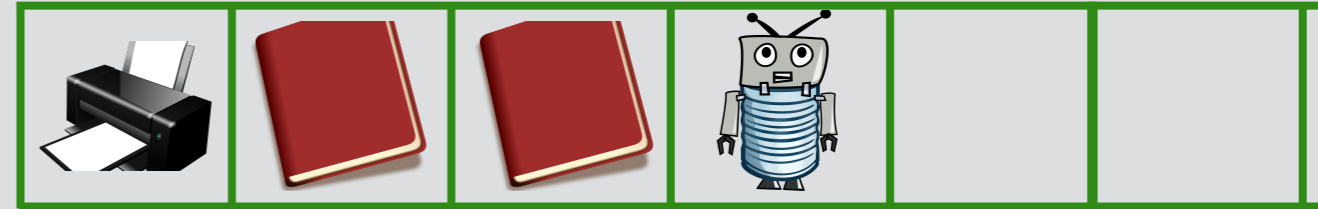

# Lola

in stars, pid

```
out isBook :=  
  if pid =  then 1 else 0
```

```
out #books :=  
  #books[-1, 0] + isBook[0, 0]
```

 offset     default

```
trigger #books >= 5  
trigger badRev
```

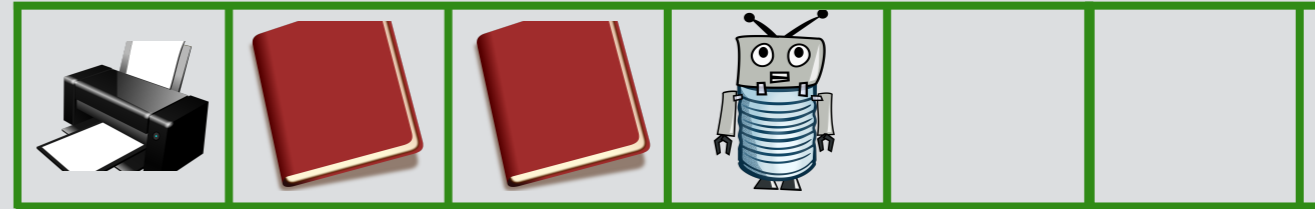

# Lola

in stars, pid

```
out isBook :=  
  if pid =  then 1 else 0
```

```
out #books :=  
  #books[-1, 0] + isBook[0, 0]
```

 offset     default

```
trigger #books >= 5  
trigger badRev
```

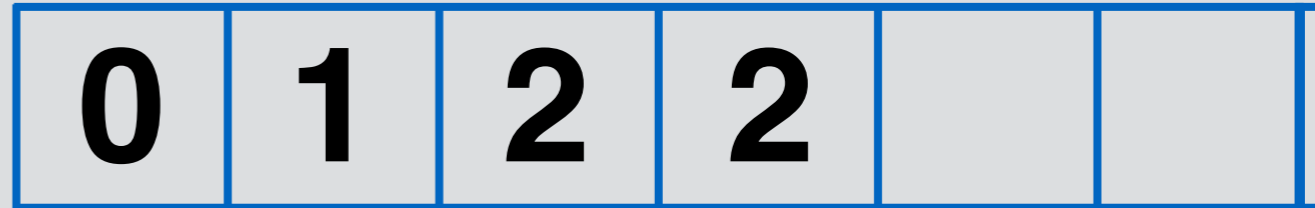
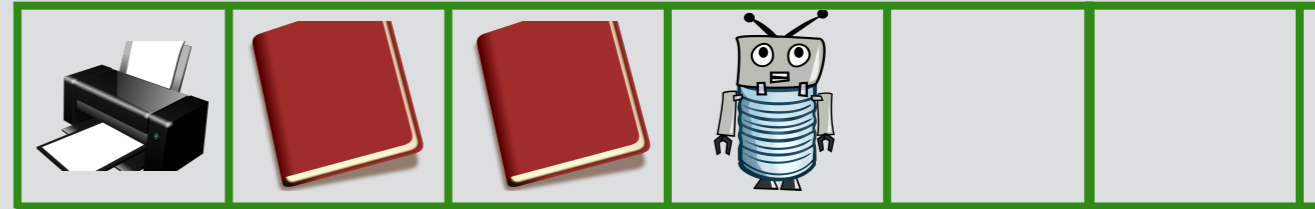

# Lola

```
in stars, pid
```

```
out isBook :=  
  if pid =  then 1 else 0
```

```
out #books :=  
  #books[-1,0]+isBook[0,0]
```

```
trigger #books >= 5
```

 book review



# Lola

```
in stars, pid
```

```
out isBook :=  
  if pid =  then 1 else 0
```

```
out #books :=  
  #books[-1,0]+isBook[0,0]
```

```
out badRev :=  
  isBook[0,0] = 1  
  and stars = 0
```

```
trigger #books >= 5  
trigger badRev
```

 book review

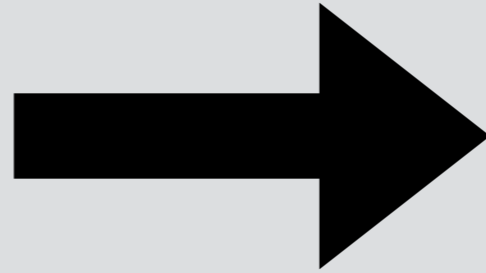

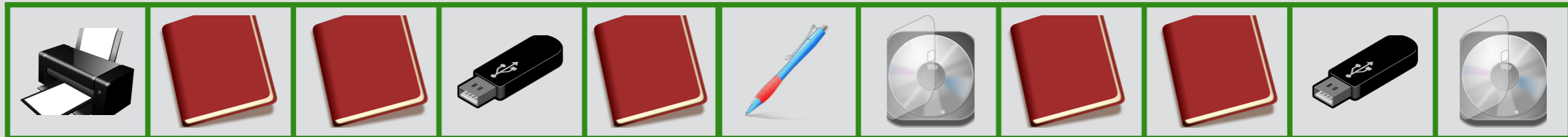
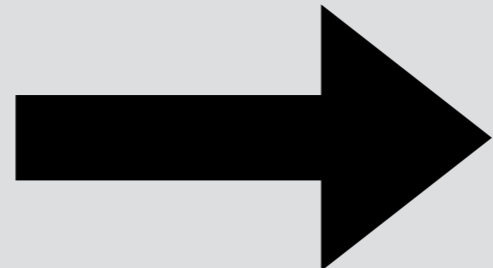



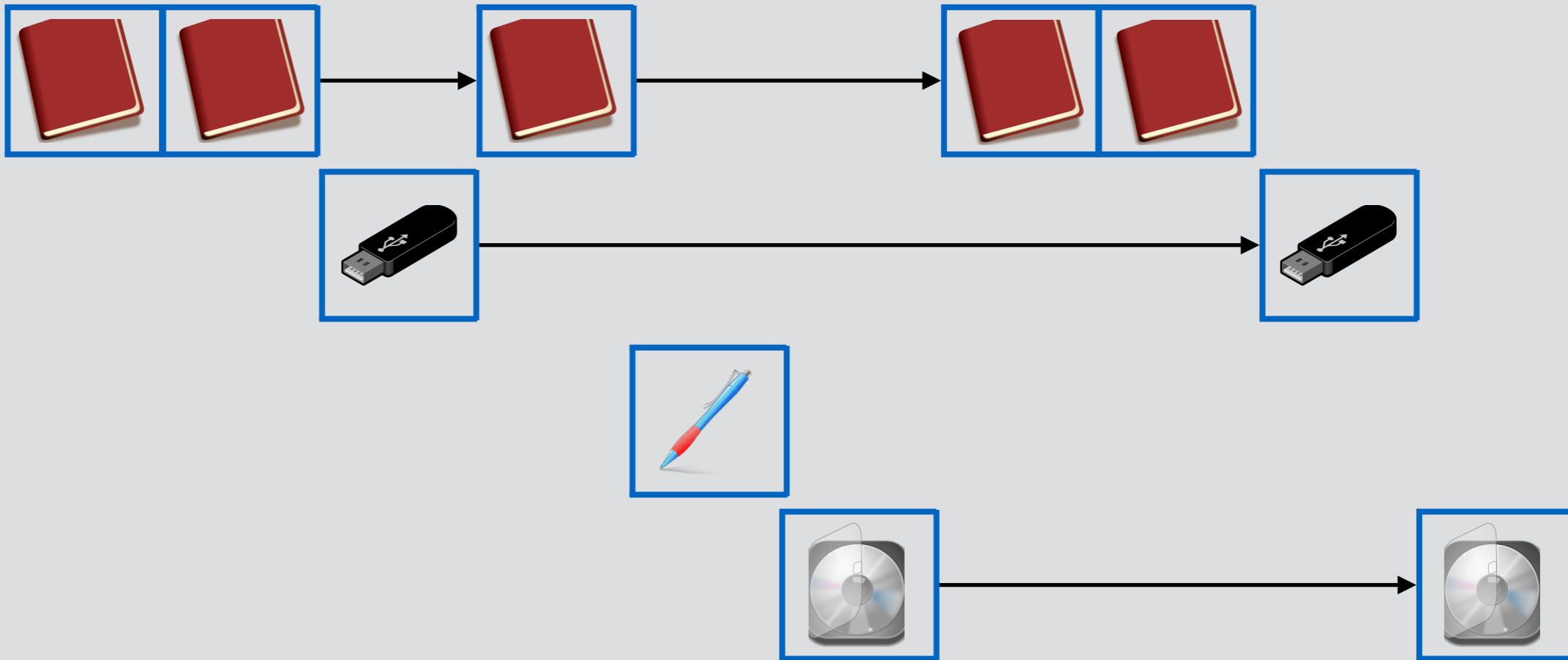
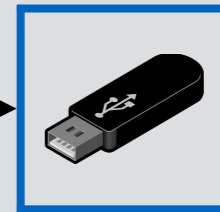
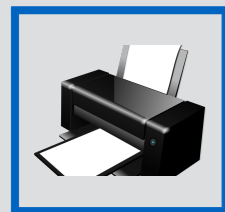
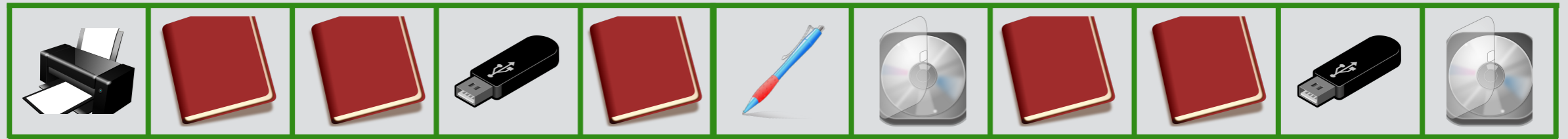

# Lola 2.0

```
in stars, pid
```

```
out split <prod>  
  inv: pid  
  ext: pid = prod  
  := stars
```

```
out inc3to4 <prod>  
  inv: pid  
  ext: pid = prod  
  := split(prod)[-1, 0] = 3  
     and stars = 4
```

```
trigger any(inc3to4)
```

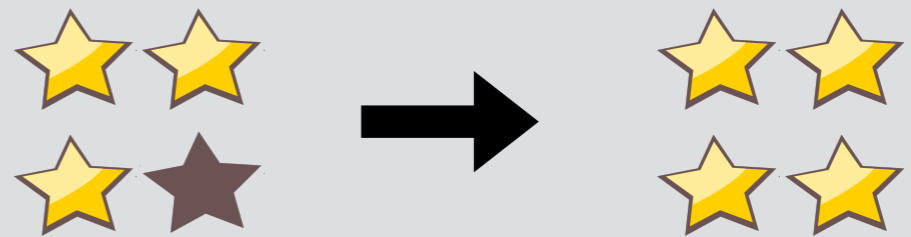

# Lola 2.0

```
in stars, pid
```

```
out split <prod>  
  inv: pid  
  ext: pid = prod  
  := stars
```

```
out inc3to4 <prod>  
  inv: pid  
  ext: pid = prod  
  := split(prod)[-1, 0] = 3  
  and stars = 4
```

```
trigger any(inc3to4)
```

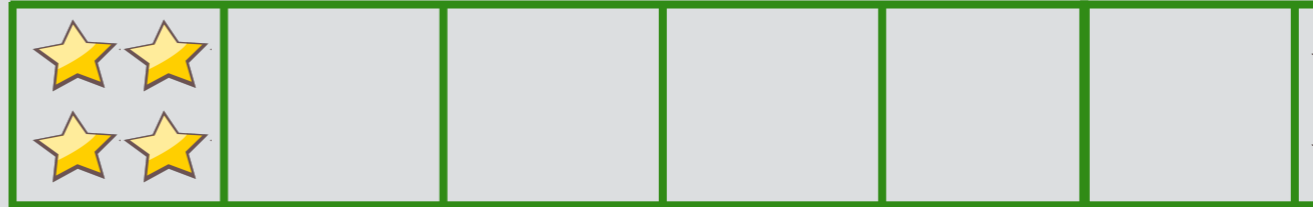

# Lola 2.0

```
in stars, pid
```

```
out split <prod>  
  inv: pid  
  ext: pid = prod  
  := stars
```

```
out inc3to4 <prod>  
  inv: pid  
  ext: pid = prod  
  := split(prod)[-1, 0] = 3  
  and stars = 4
```

```
trigger any(inc3to4)
```

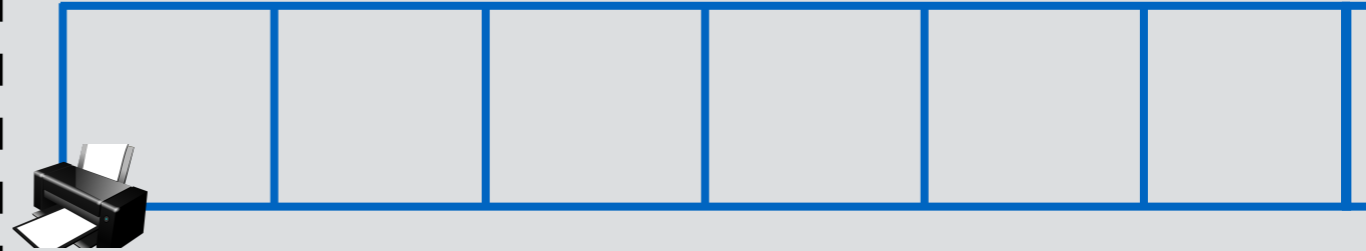



# Lola 2.0

```
in stars, pid
```

```
out split <prod>  
  inv: pid  
  ext: pid = prod  
  := stars
```

```
out inc3to4 <prod>  
  inv: pid  
  ext: pid = prod  
  := split(prod)[-1, 0] = 3  
  and stars = 4
```

```
trigger any(inc3to4)
```

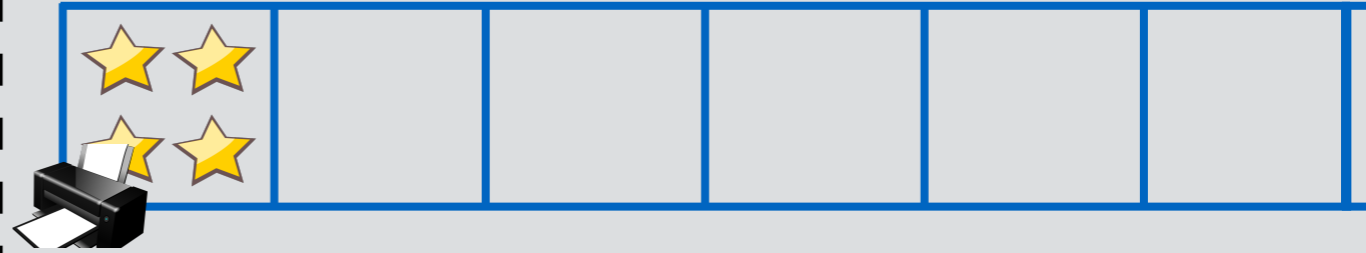

# Lola 2.0

```
in stars, pid
```

```
out split <prod>  
  inv: pid  
  ext: pid = prod  
  := stars
```

```
out inc3to4 <prod>  
  inv: pid  
  ext: pid = prod  
  := split(prod)[-1, 0] = 3  
  and stars = 4
```

```
trigger any(inc3to4)
```

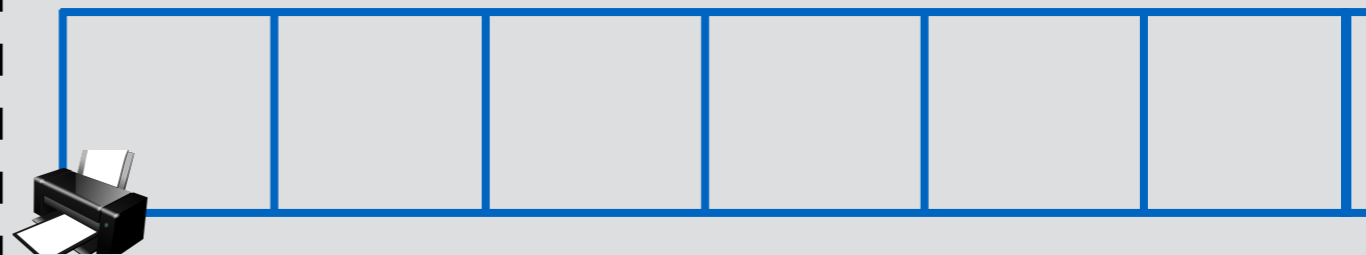
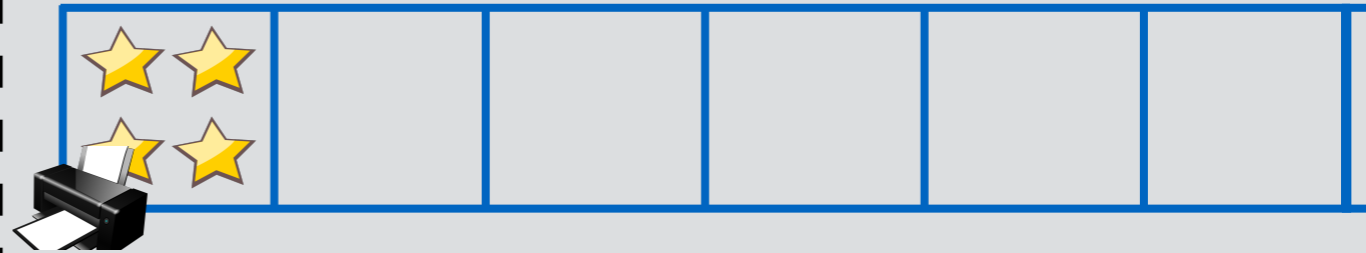

# Lola 2.0

```
in stars, pid
```

```
out split <prod>  
  inv: pid  
  ext: pid = prod  
  := stars
```

```
out inc3to4 <prod>  
  inv: pid  
  ext: pid = prod  
  := split(prod)[-1, 0] = 3  
  and stars = 4
```

```
trigger any(inc3to4)
```

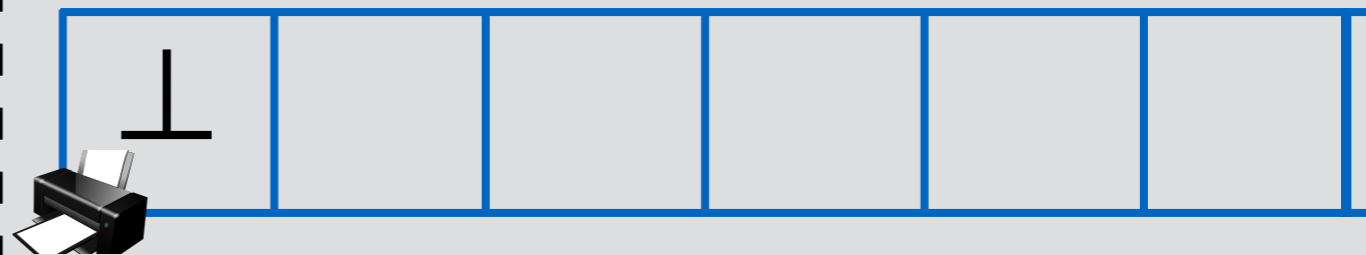
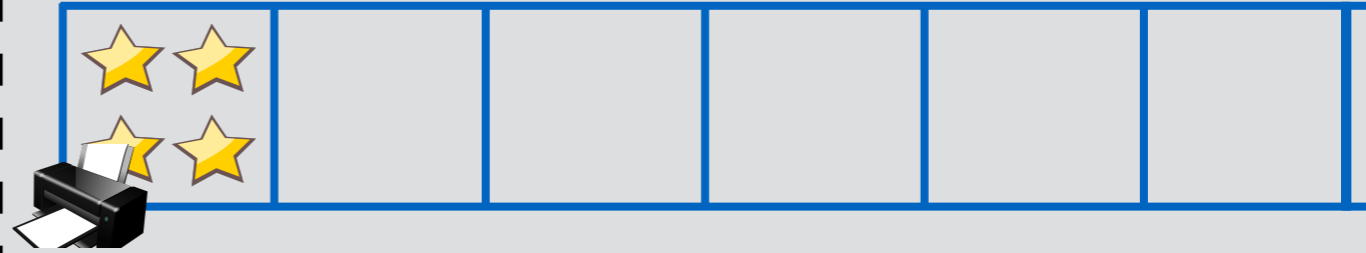

# Lola 2.0

```
in stars, pid
```

```
out split <prod>  
  inv: pid  
  ext: pid = prod  
  := stars
```

```
out inc3to4 <prod>  
  inv: pid  
  ext: pid = prod  
  := split(prod)[-1, 0] = 3  
  and stars = 4
```

```
trigger any(inc3to4)
```

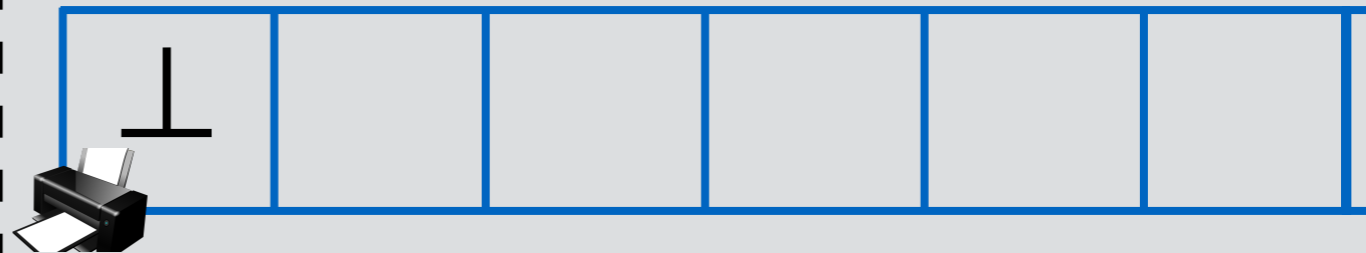
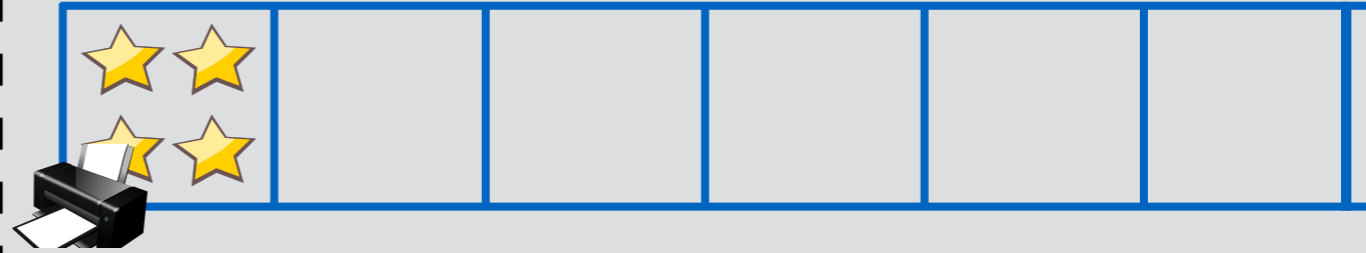

# Lola 2.0

```
in stars, pid
```

```
out split <prod>  
  inv: pid  
  ext: pid = prod  
  := stars
```

```
out inc3to4 <prod>  
  inv: pid  
  ext: pid = prod  
  := split(prod)[-1, 0] = 3  
  and stars = 4
```

```
trigger any(inc3to4)
```

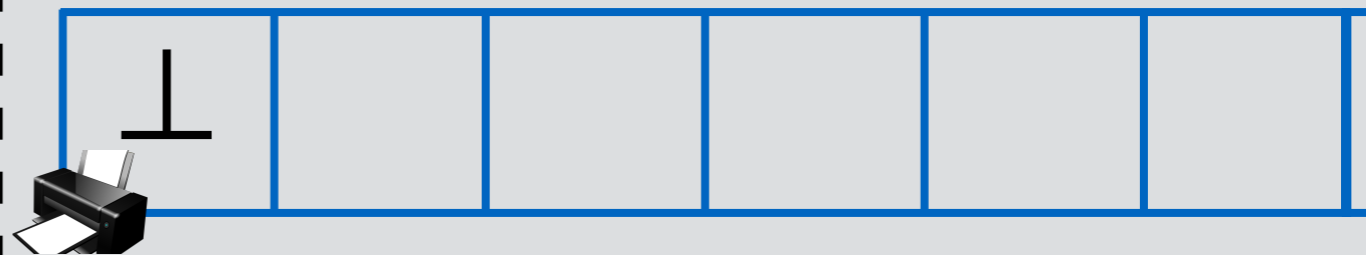
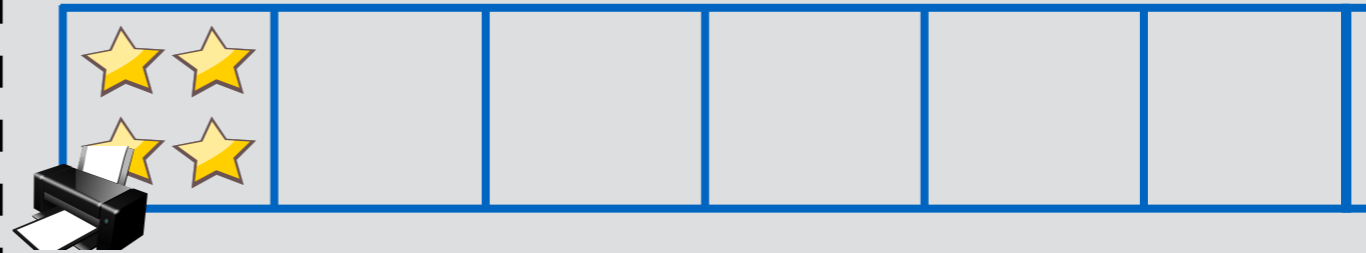

# Lola 2.0

```
in stars, pid
```

```
out split <prod>  
  inv: pid  
  ext: pid = prod  
  := stars
```

```
out inc3to4 <prod>  
  inv: pid  
  ext: pid = prod  
  := split(prod)[-1, 0] = 3  
  and stars = 4
```

```
trigger any(inc3to4)
```

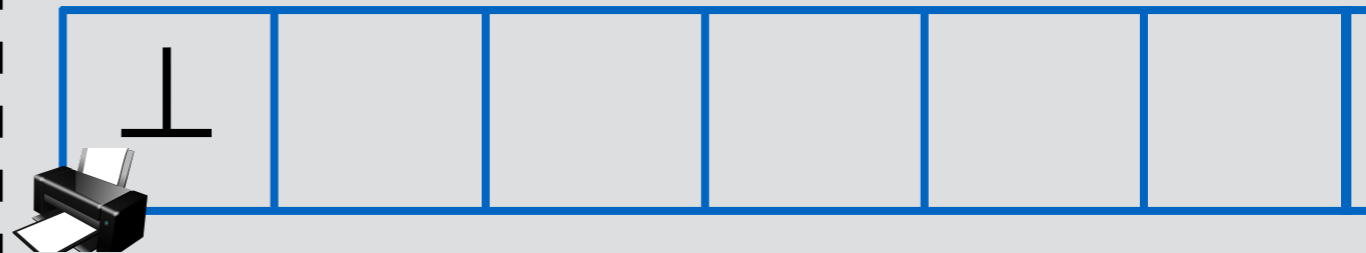
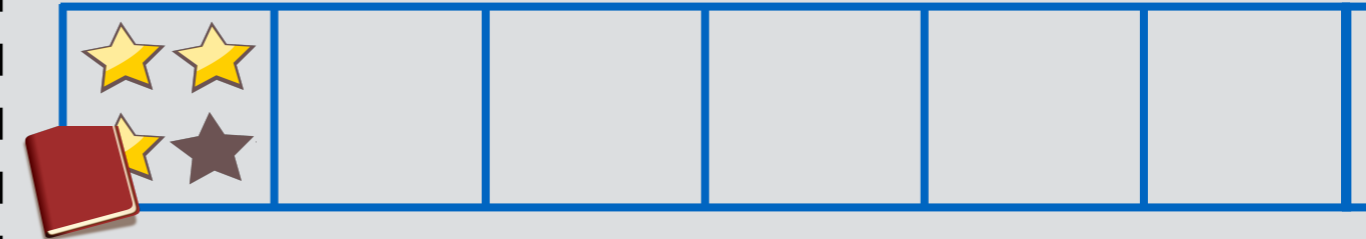
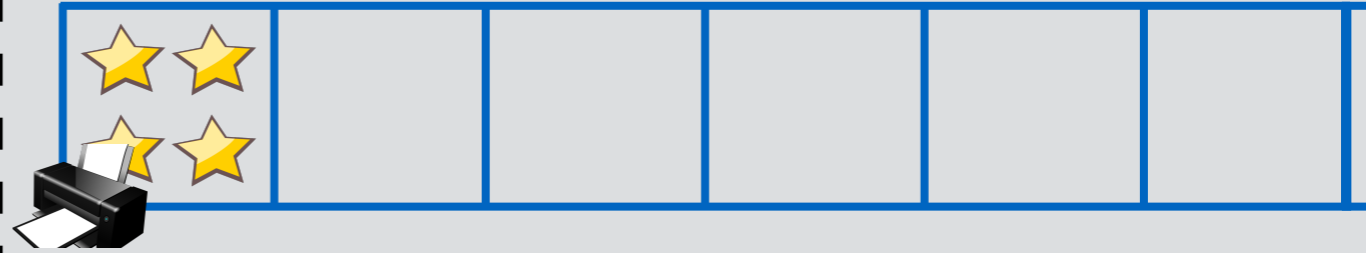

# Lola 2.0

```
in stars, pid
```

```
out split <prod>  
  inv: pid  
  ext: pid = prod  
  := stars
```

```
out inc3to4 <prod>  
  inv: pid  
  ext: pid = prod  
  := split(prod)[-1, 0] = 3  
  and stars = 4
```

```
trigger any(inc3to4)
```

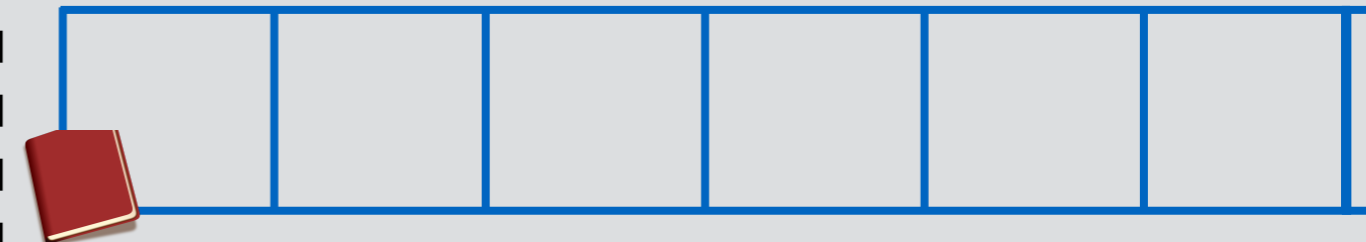
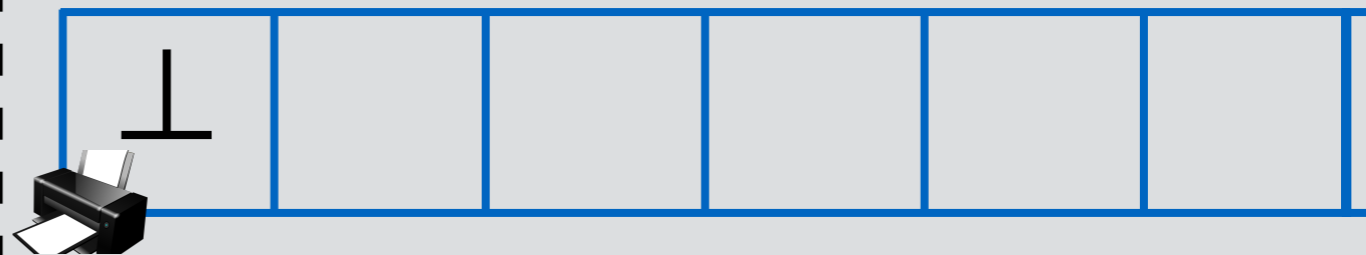
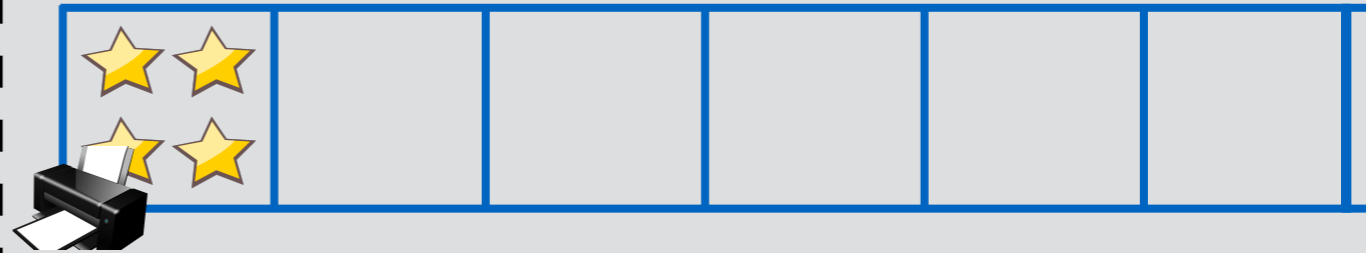

# Lola 2.0

```
in stars, pid
```

```
out split <prod>  
  inv: pid  
  ext: pid = prod  
  := stars
```

```
out inc3to4 <prod>  
  inv: pid  
  ext: pid = prod  
  := split(prod)[-1, 0] = 3  
  and stars = 4
```

```
trigger any(inc3to4)
```

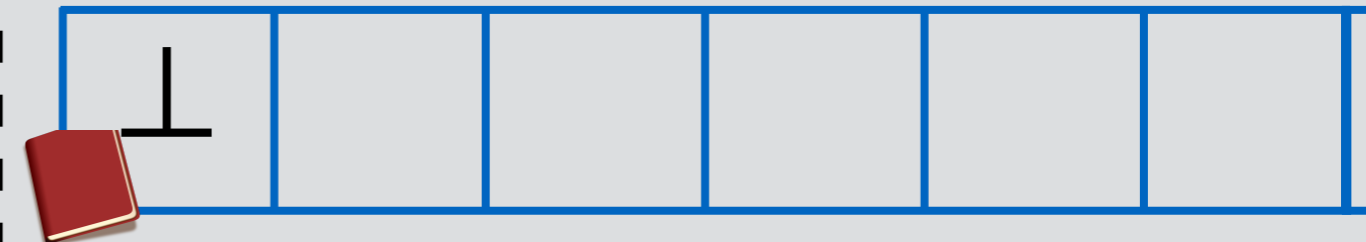
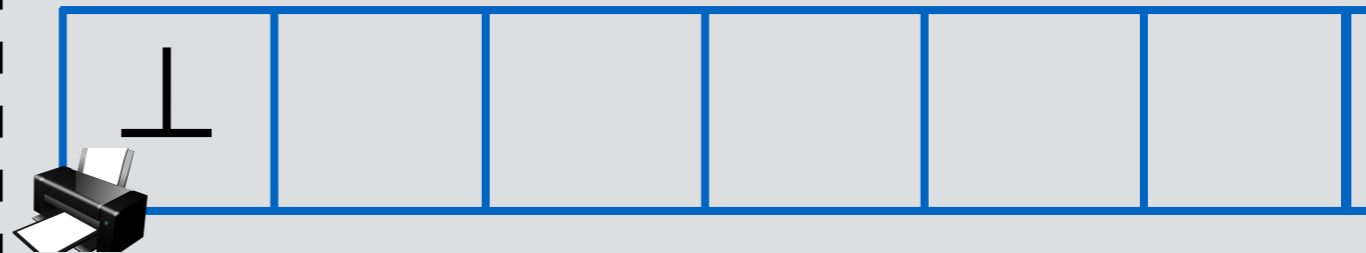
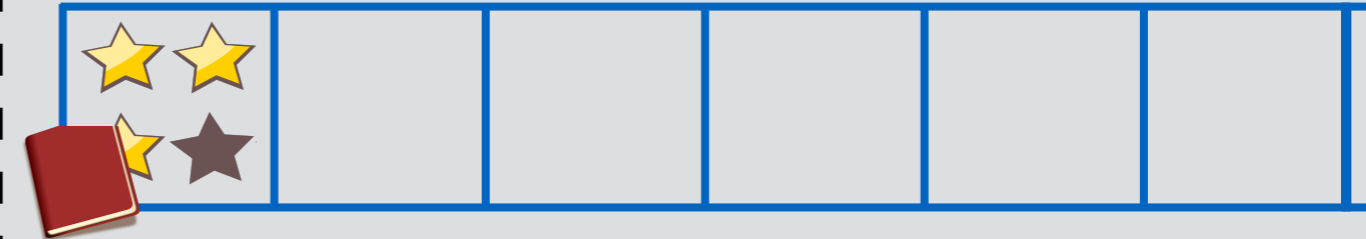
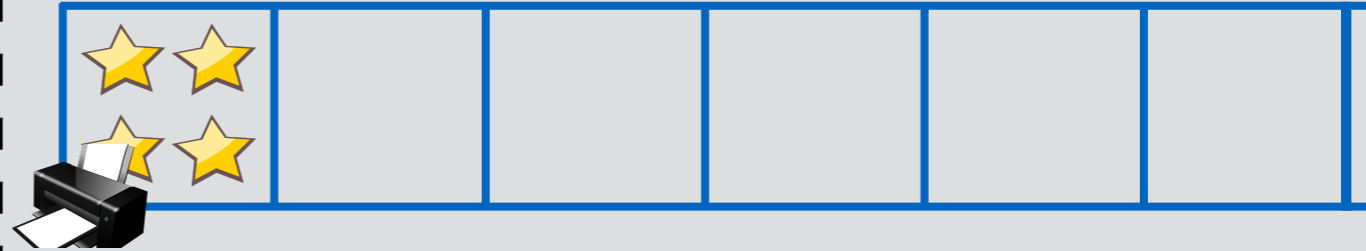



# Lola 2.0

```
in stars, pid
```

```
out split <prod>  
  inv: pid  
  ext: pid = prod  
  := stars
```

```
out inc3to4 <prod>  
  inv: pid  
  ext: pid = prod  
  := split(prod)[-1, 0] = 3  
  and stars = 4
```

```
trigger any(inc3to4)
```

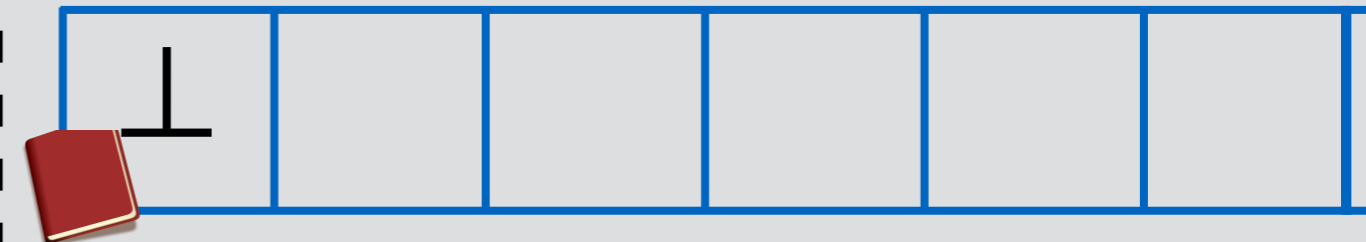
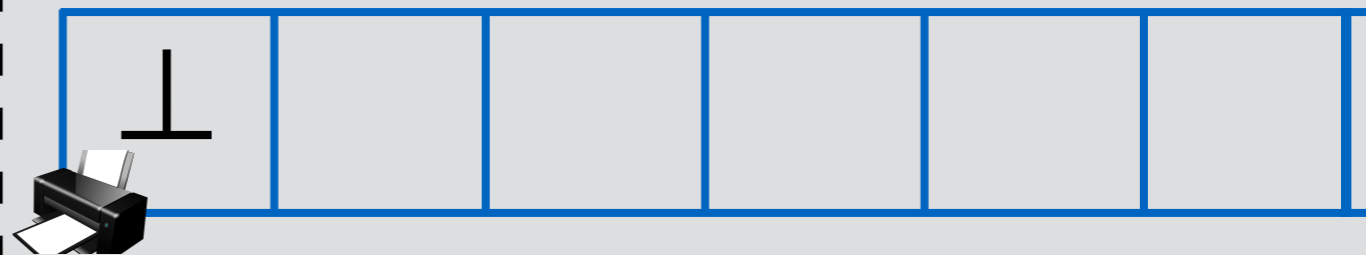
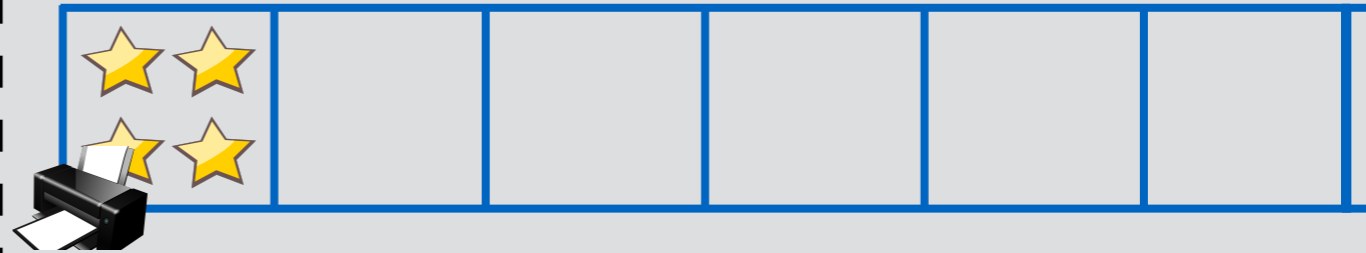

# Lola 2.0

```
in stars, pid
```

```
out split <prod>  
  inv: pid  
  ext: pid = prod  
  := stars
```

```
out inc3to4 <prod>  
  inv: pid  
  ext: pid = prod  
  := split(prod)[-1, 0] = 3  
  and stars = 4
```

```
trigger any(inc3to4)
```

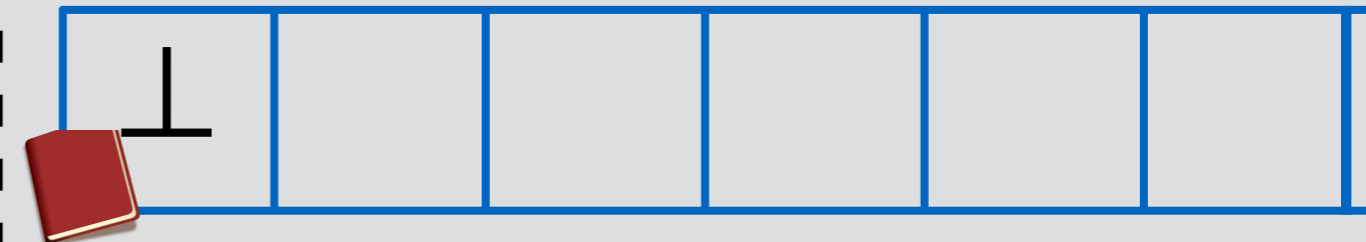
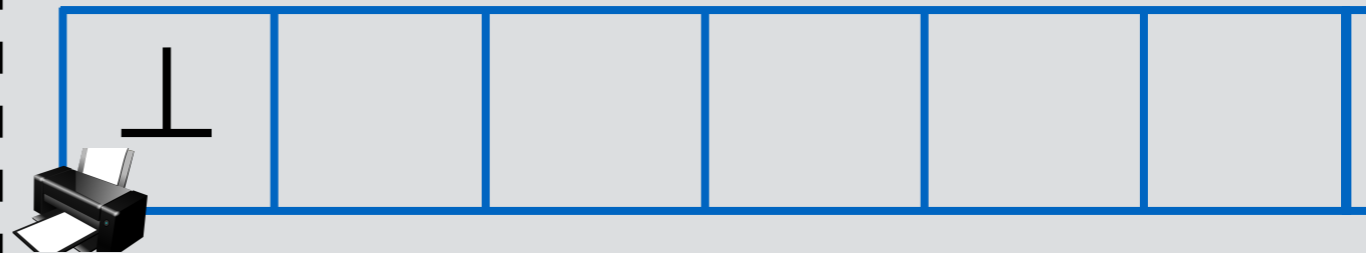
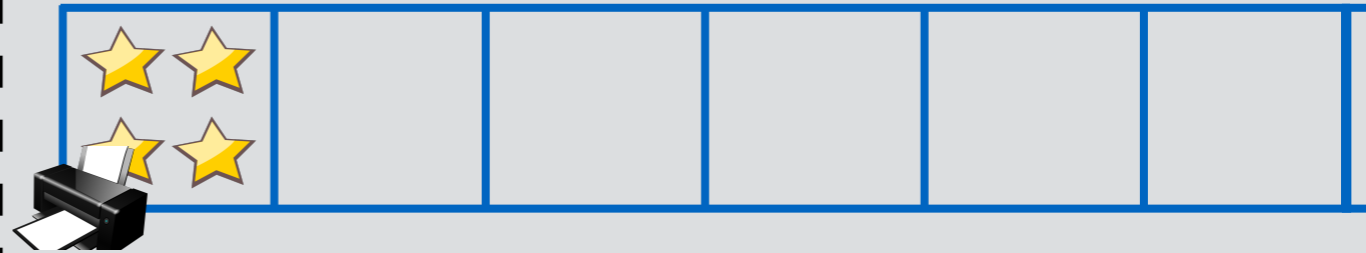

# Lola 2.0

```
in stars, pid
```

```
out split <prod>  
  inv: pid  
  ext: pid = prod  
  := stars
```

```
out inc3to4 <prod>  
  inv: pid  
  ext: pid = prod  
  := split(prod)[-1, 0] = 3  
  and stars = 4
```

```
trigger any(inc3to4)
```

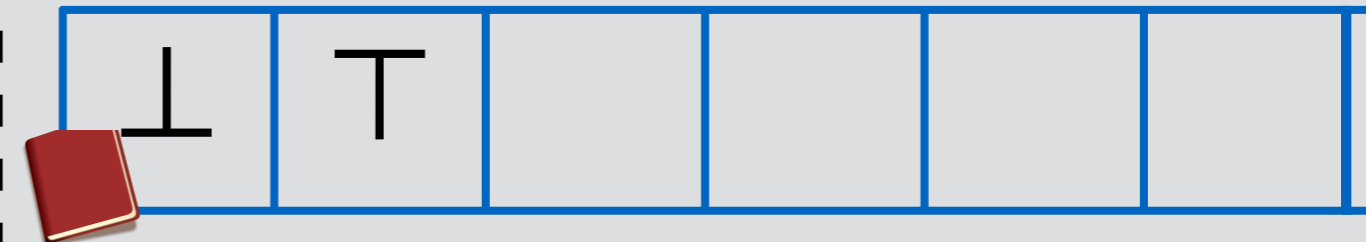
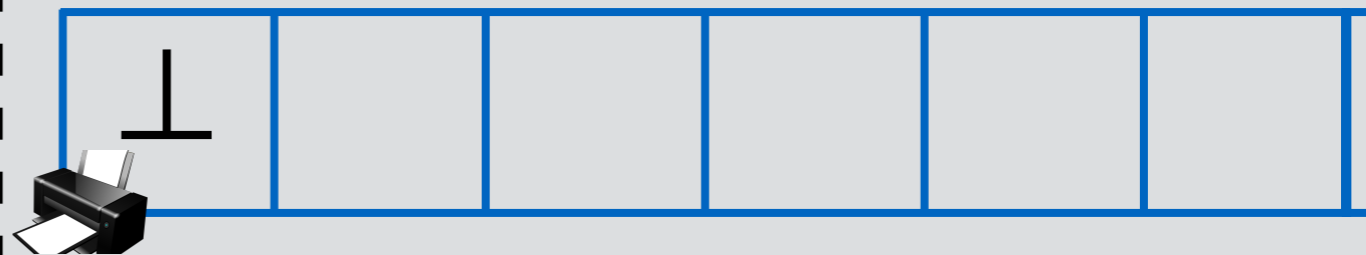
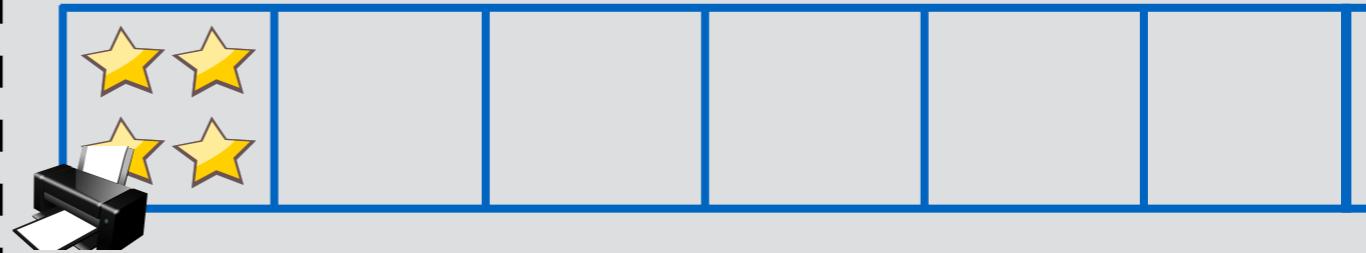

# *Real-Time Lola 2.0*

## **Real-time Stream Monitoring**

Peter Faymonville, Bernd Finkbeiner, Maximilian Schwenger, and Hazem Torfah

Saarland University

{faymonville, finkbeiner, schwenger, torfah}@react.uni-saarland.de

**Abstract.** We introduce a new stream-based specification language for the description of real-time properties of reactive systems. The key feature

# *Real-Time Lola 2.0*

**Rapid** increase in page views?

Average number of reviews **per month**?

**Hourly** rate of new book reviews?

# *Real-Time Lola 2.0*

Rapid **increase** in page views?

**Average** number of reviews **per month**?

**Hourly rate** of new book reviews?

# Real-Time Lola 2.0

10s



# Real-Time Lola 2.0

10s



$W_1$



# Real-Time Lola 2.0

10s



# Real-Time Lola 2.0

10s



# Real-Time Lola 2.0

10s



# Aggregation $\gamma$

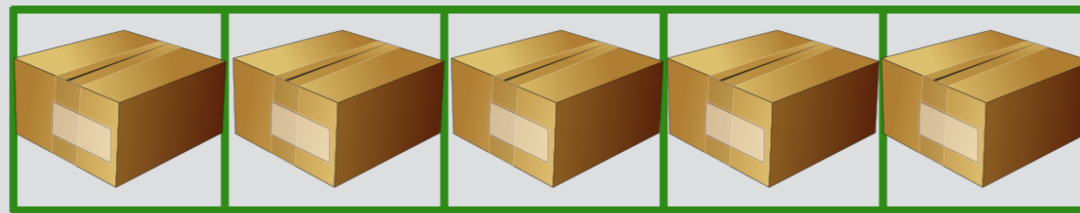

# Aggregation $\gamma$

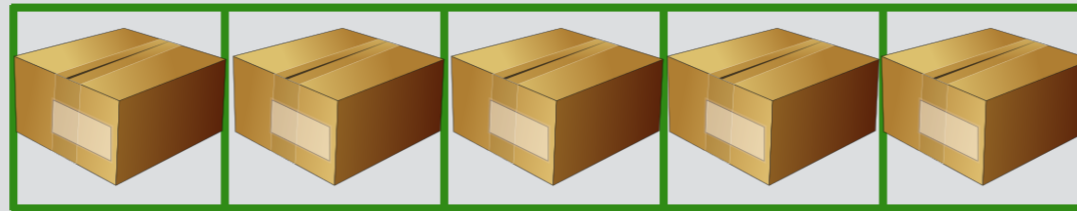
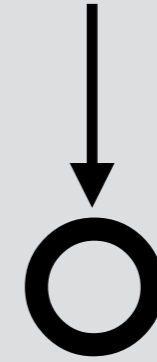

# Aggregation $\gamma$

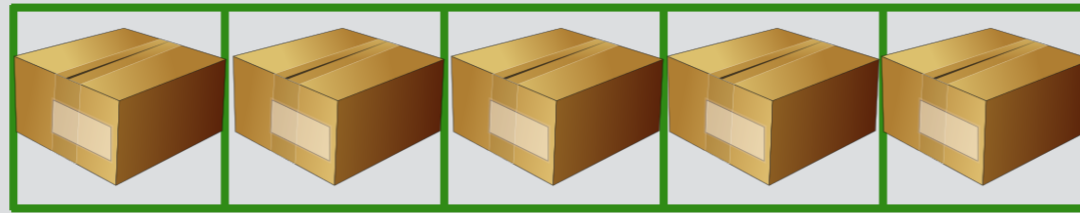
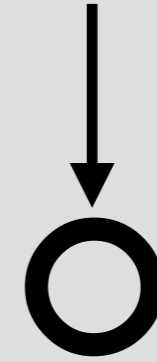

# Aggregation $\gamma$

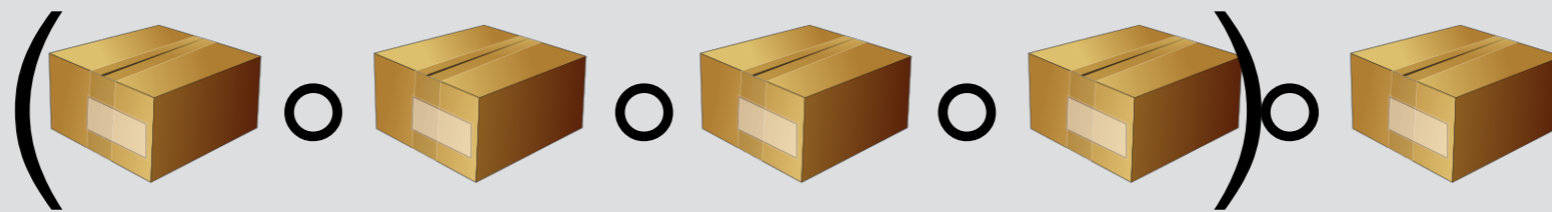
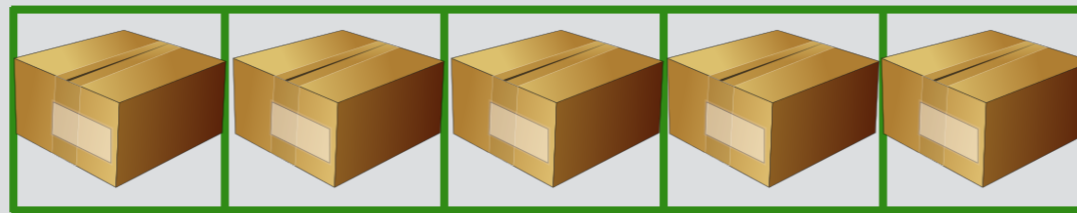
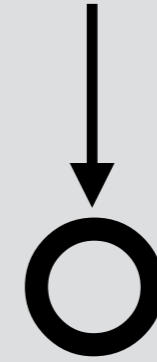

# Aggregation $\gamma$

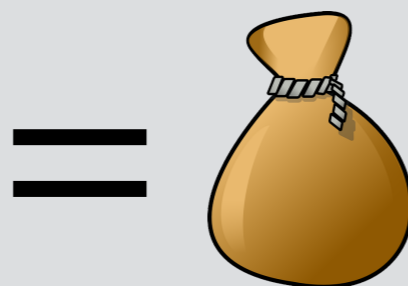
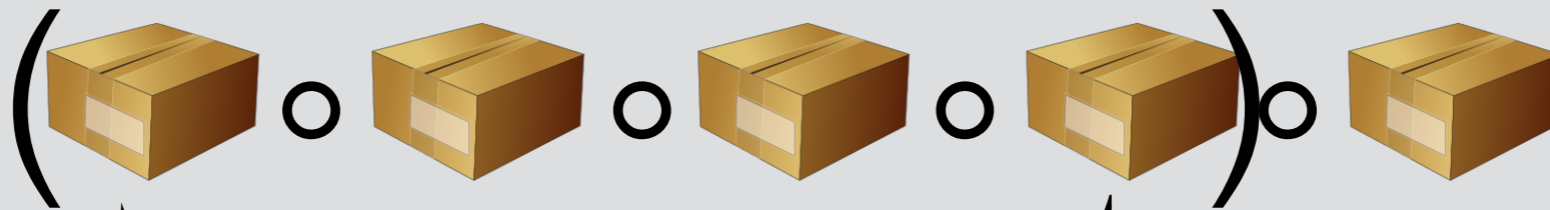
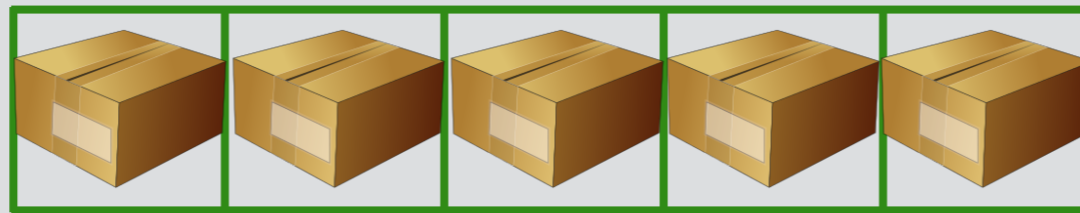
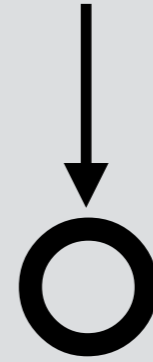



# Aggregation $\gamma$

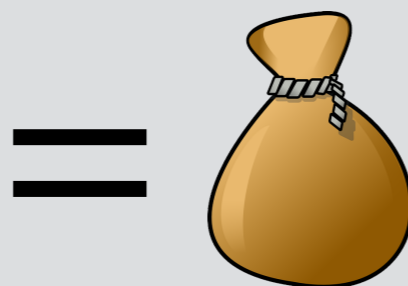
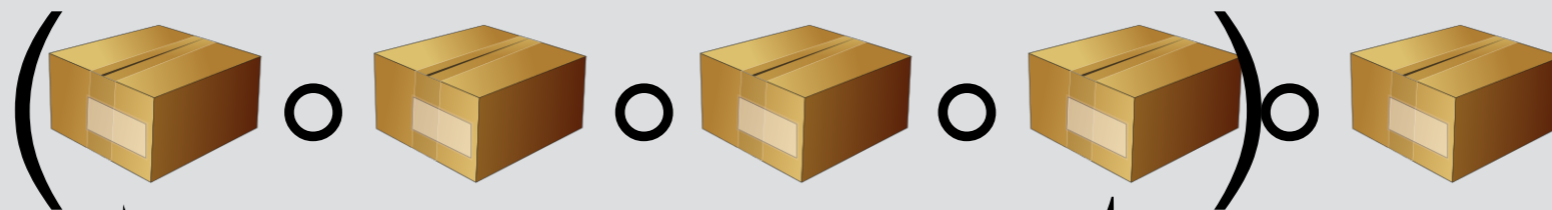
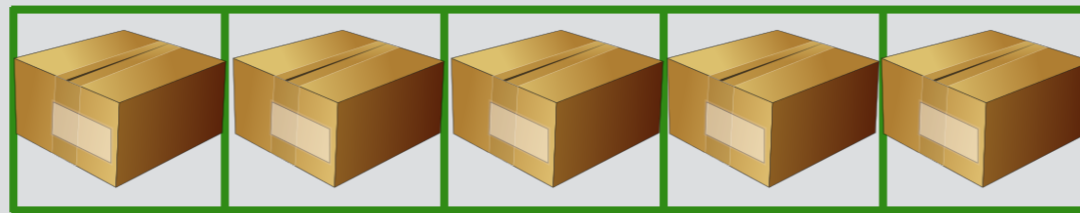
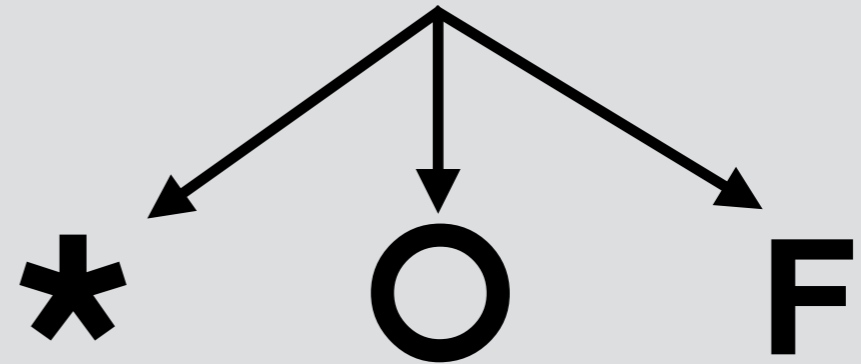

# Sound Split

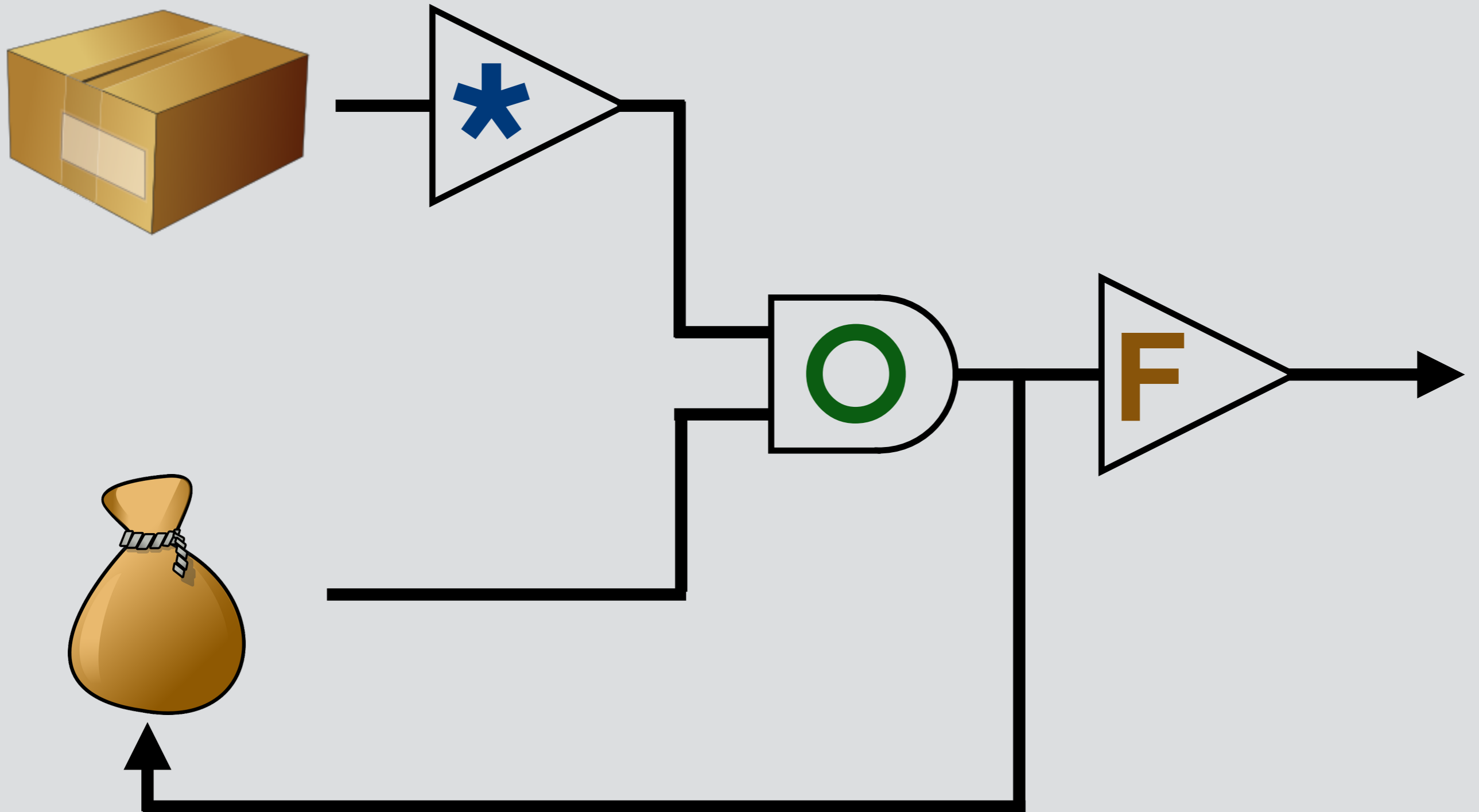

# Sound Split

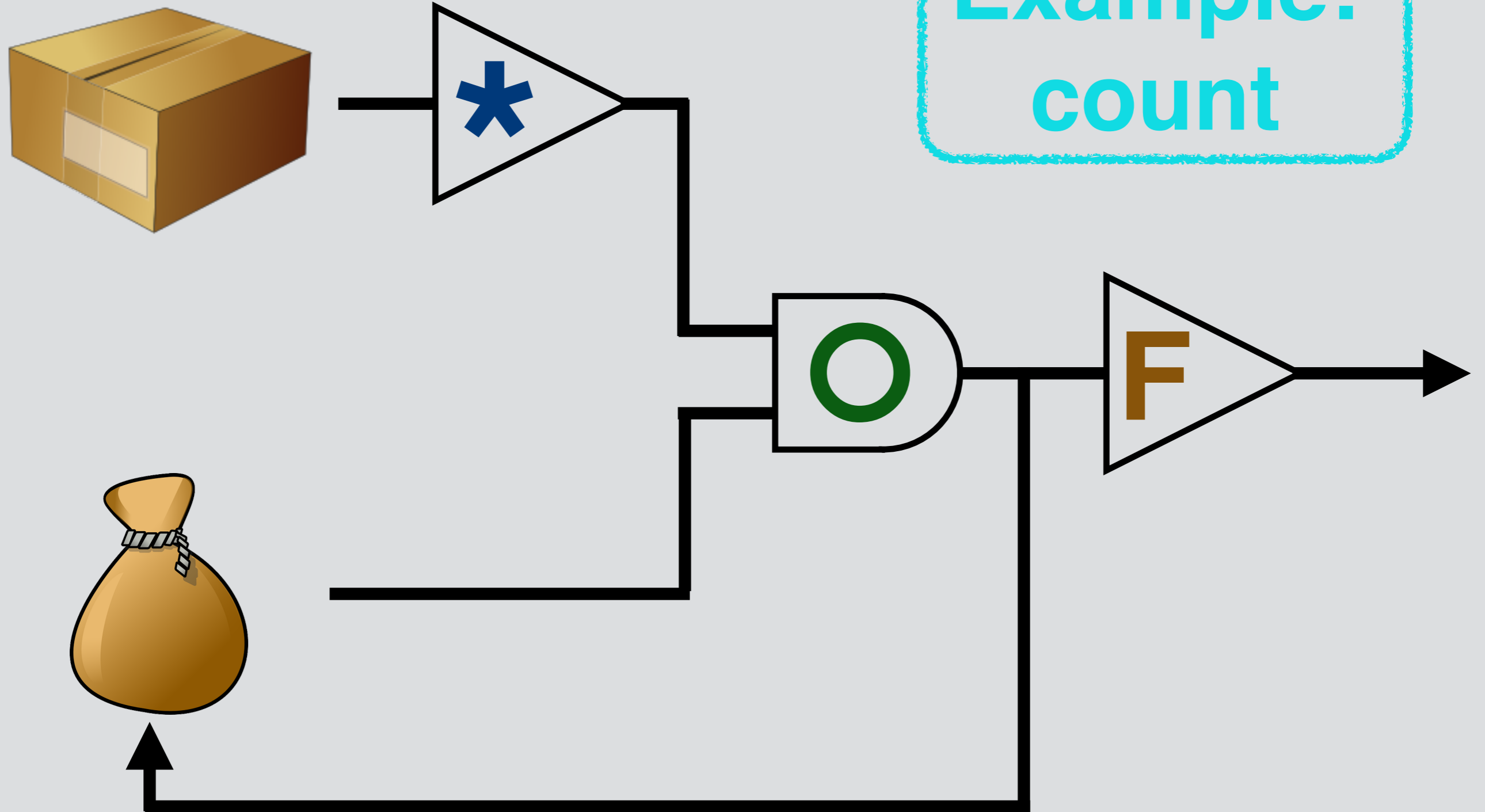

# Sound Split

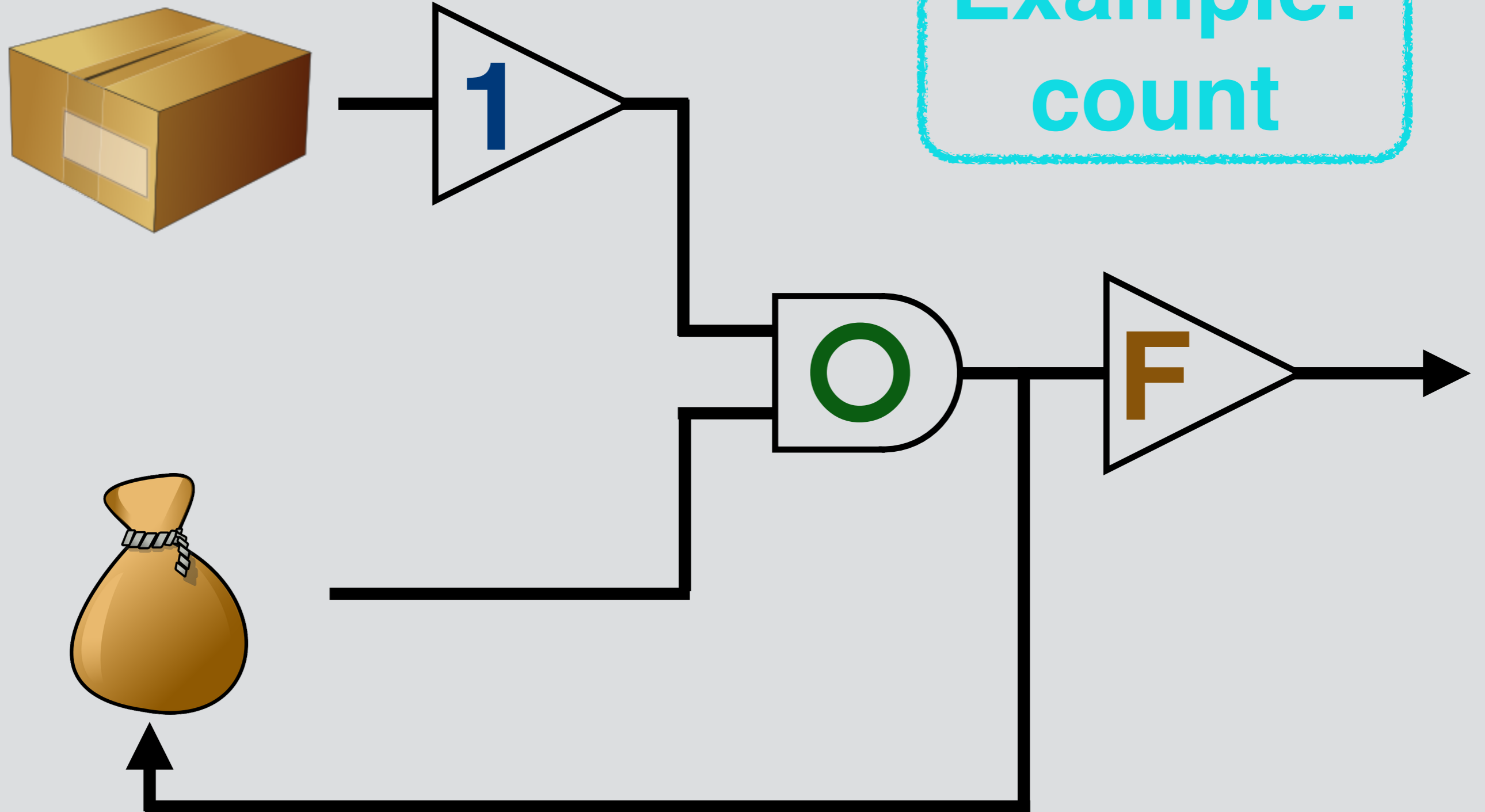

**Example:  
count**

# Sound Split

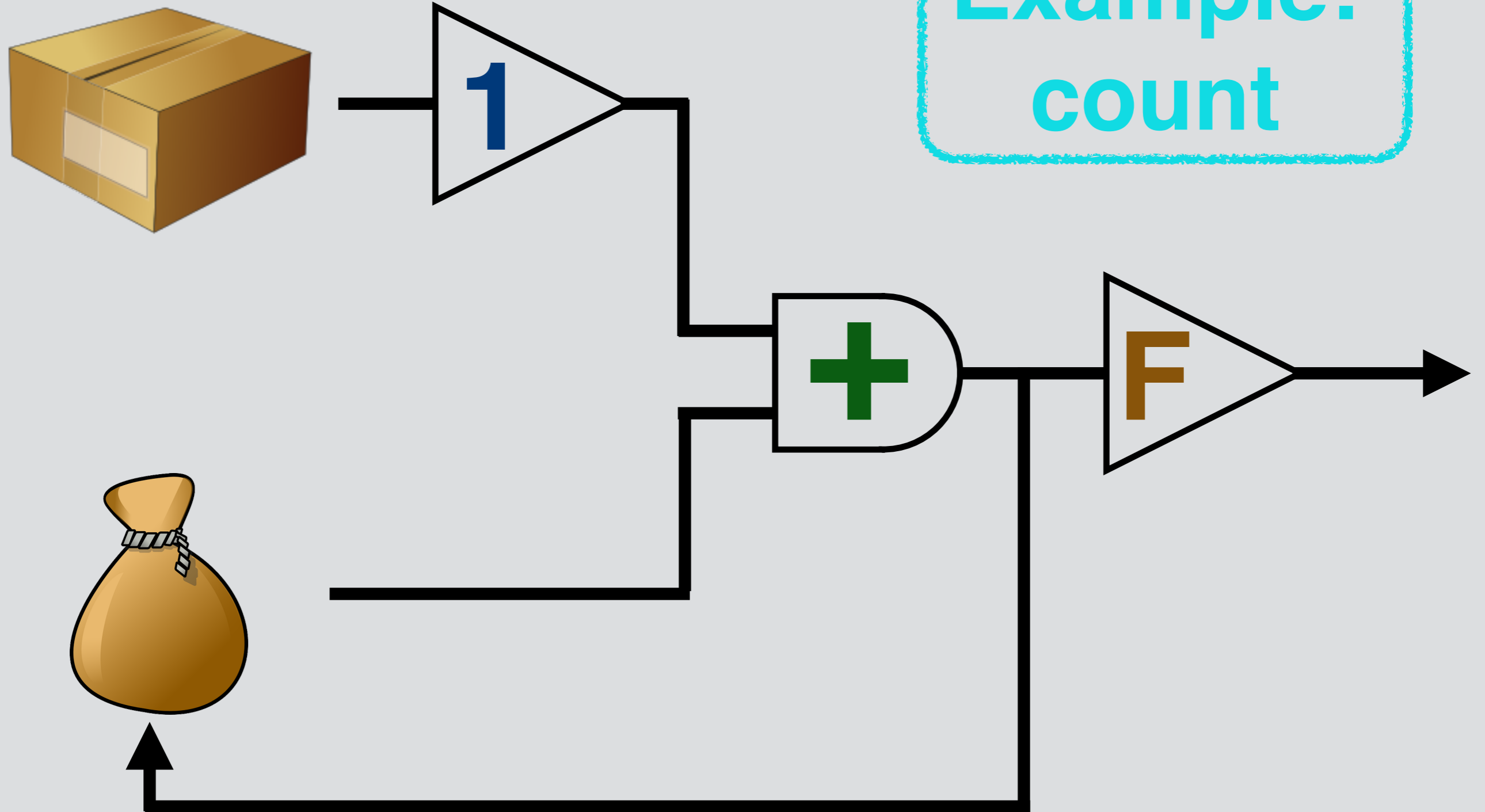

# Sound Split

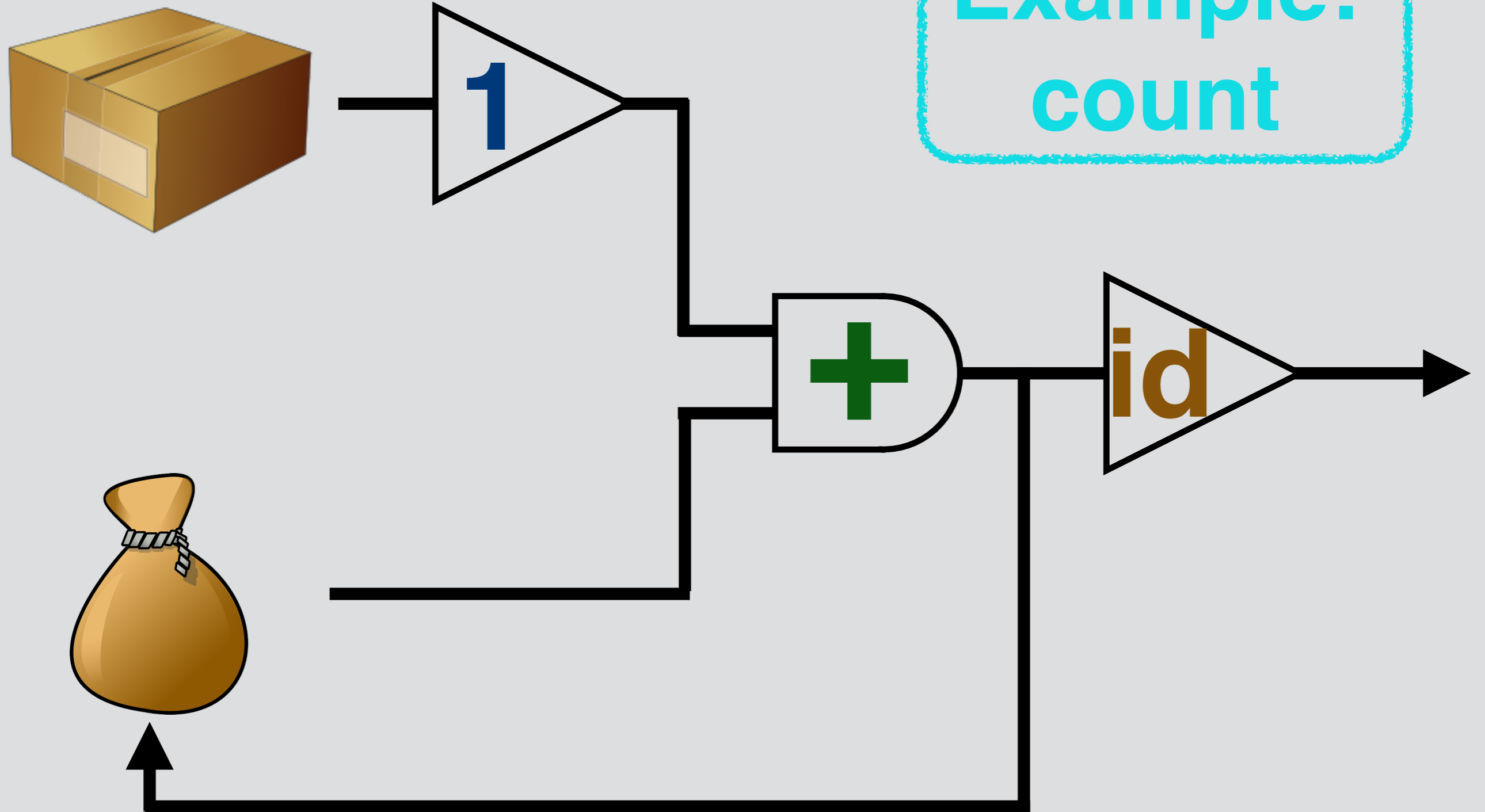

# Sound Split

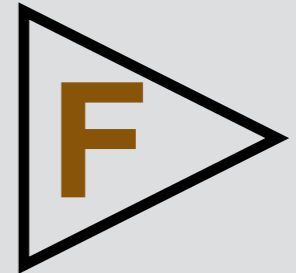
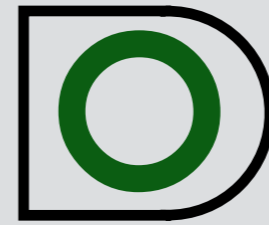

**count**

$x \mapsto 1$

+

id

# Sound Split

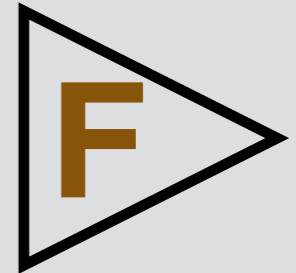
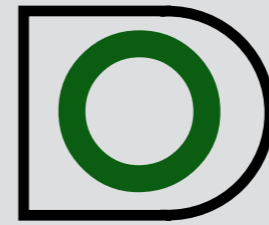
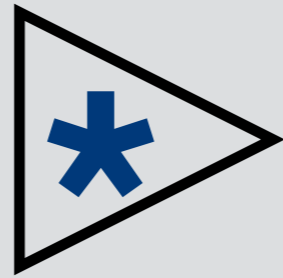

**count**

$x \mapsto 1$

+

id

**average**

$x \mapsto (x, 1)$

+

$(a, b) \mapsto a/b$



# Sound Split

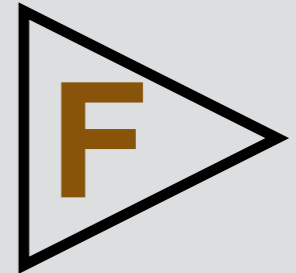
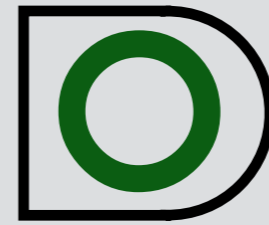
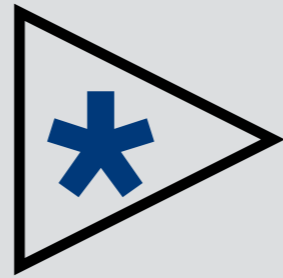

**count**

$x \mapsto 1$

+

id

**average**

$x \mapsto (x, 1)$

+

$(a, b) \mapsto a/b$

**median**

impossible

# Sound Split

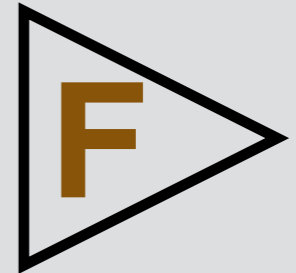
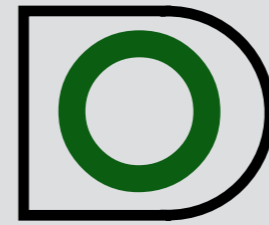
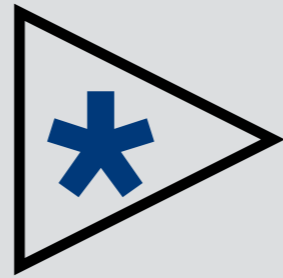

**count**

$x \mapsto 1$

+

id

**average**

$x \mapsto (x, 1)$

+

$(a, b) \mapsto a/b$

**median**

impossible

**“integral”**

trapezoid

+

id

# Real-Time Lola 2.0

10s



# Real-Time Lola 2.0

10s



# Real-Time Lola 2.0



# Aggregation $\gamma$

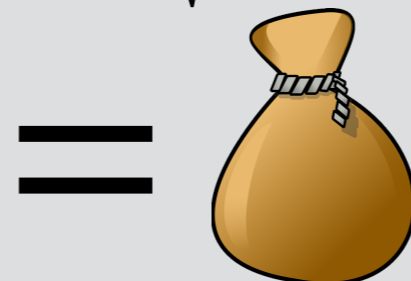
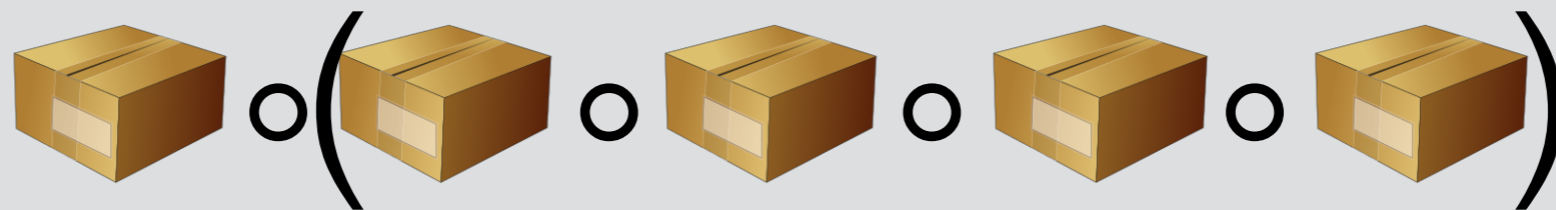
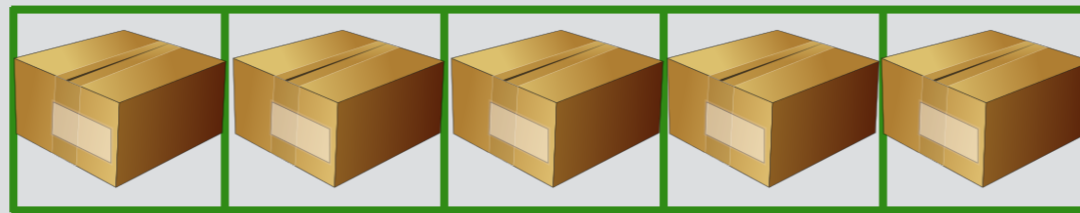
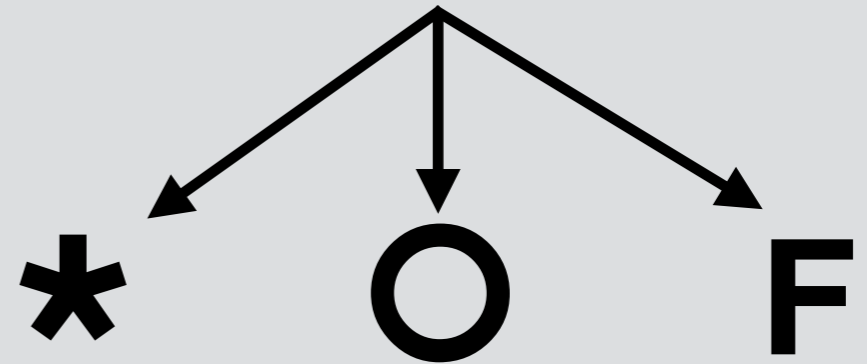

# Aggregation $\gamma$

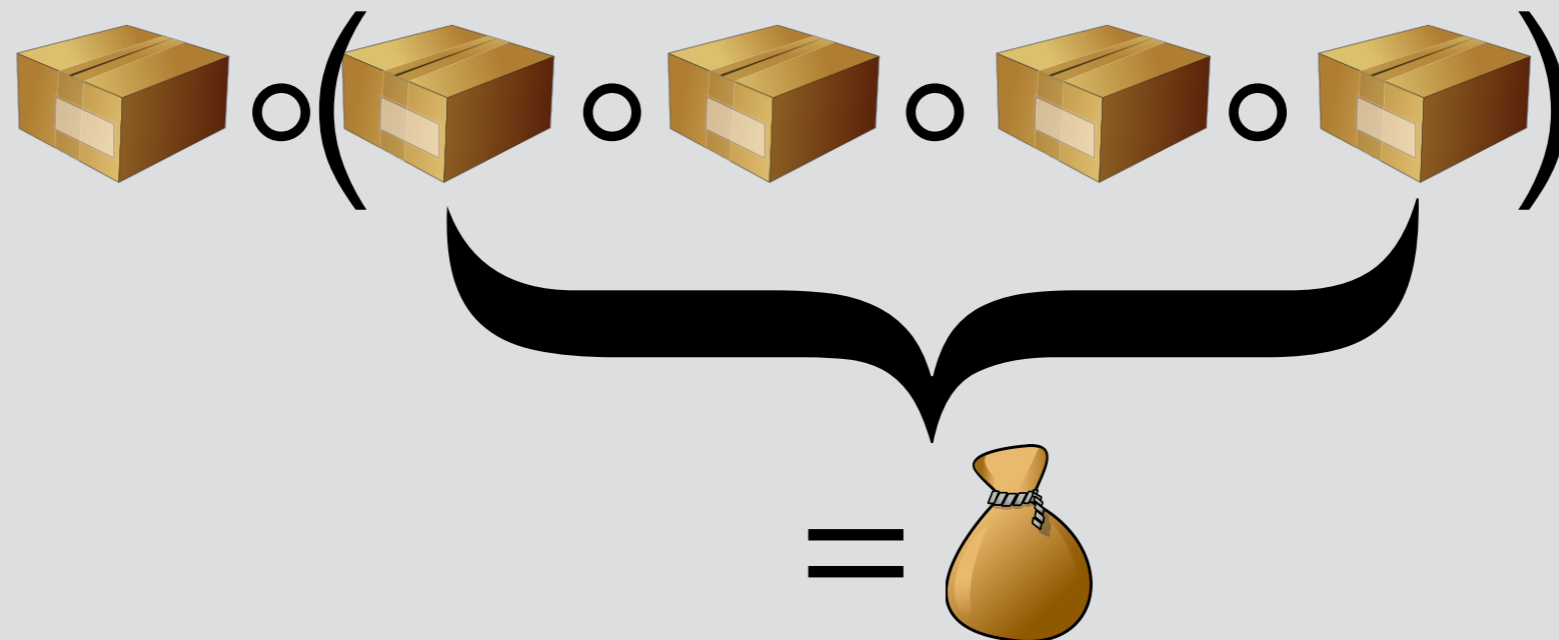
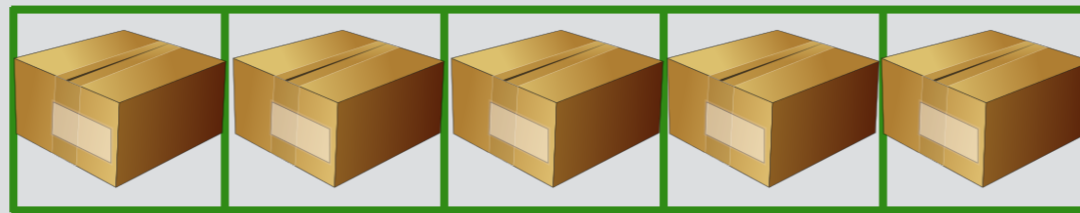
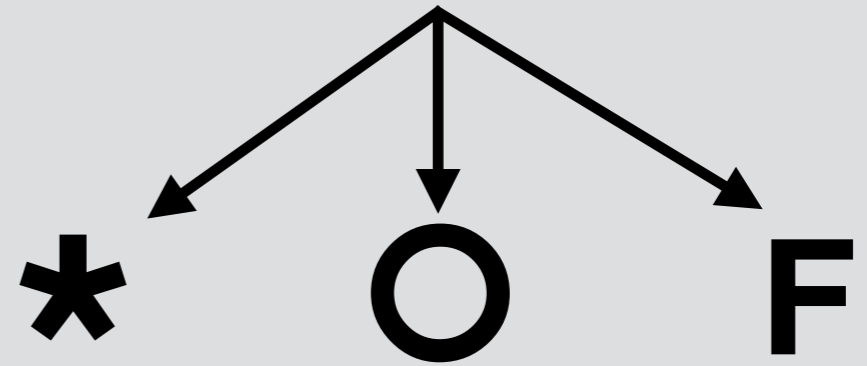

# Left-Invertibility of $\circ$

$$a \circ b = c \iff \circ^{-1}(c, a) = b$$



# Left-Invertibility of $\circ$

$$a \circ b = c \iff \circ^{-1}(c, a) = b$$

$$3 + 4 = 7 \iff +^{-1}(7, 3) = 4$$

# Left-Invertibility of $\circ$

$$a \circ b = c \iff \circ^{-1}(c, a) = b$$

$$3 + 4 = 7 \iff +^{-1}(7, 3) = 4$$

$$\max(12, 9) = 12 \iff \max^{-1}(12, 12) = ?$$

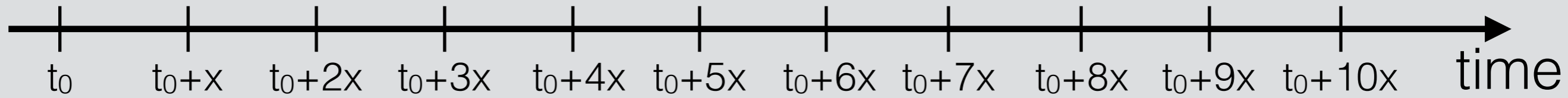
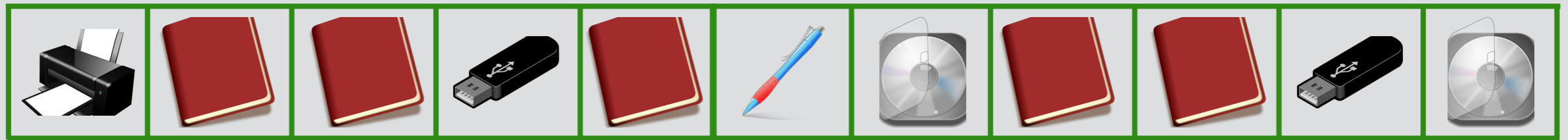

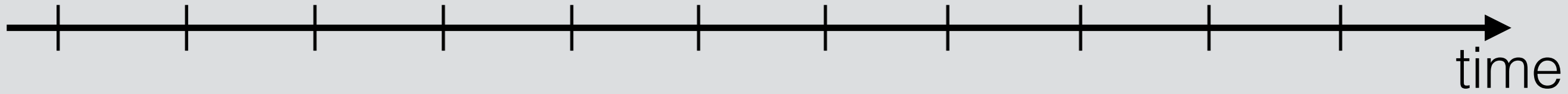

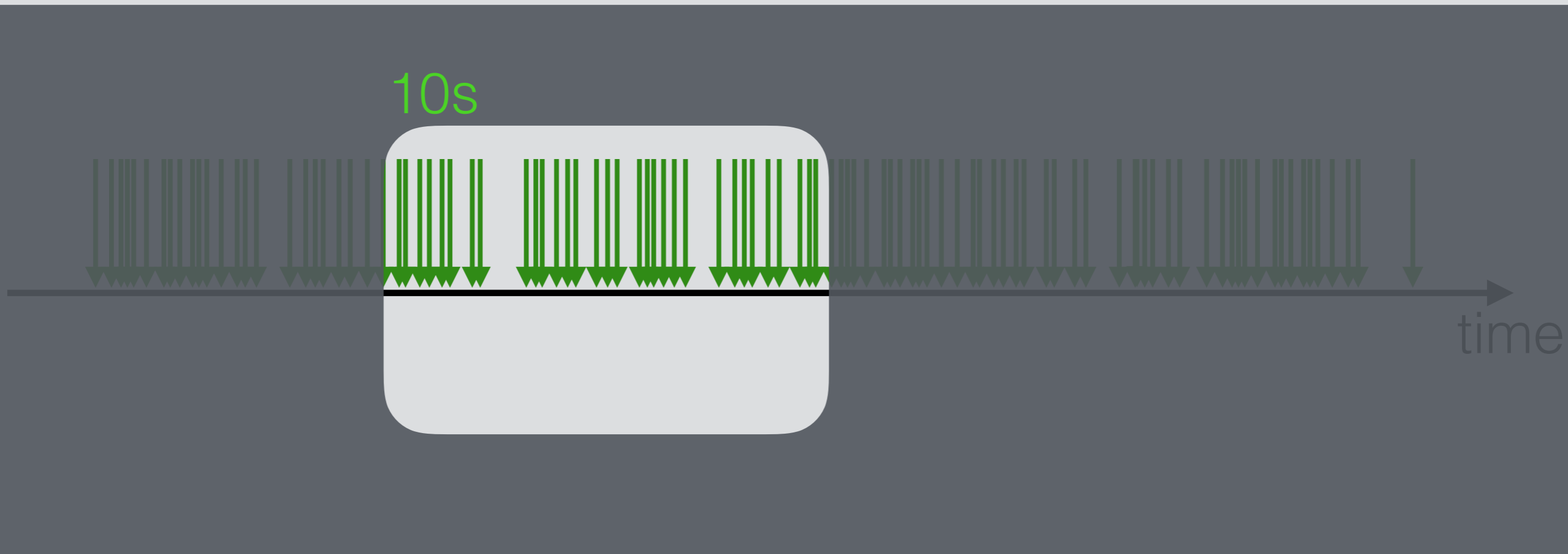

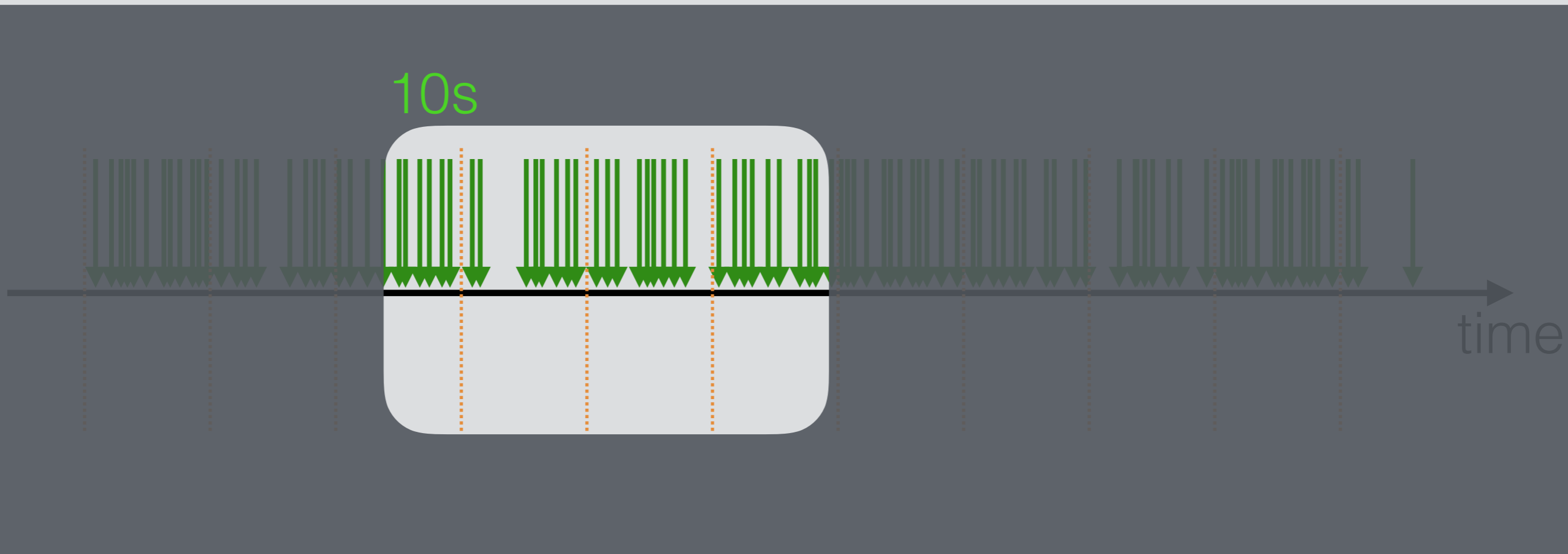

10s

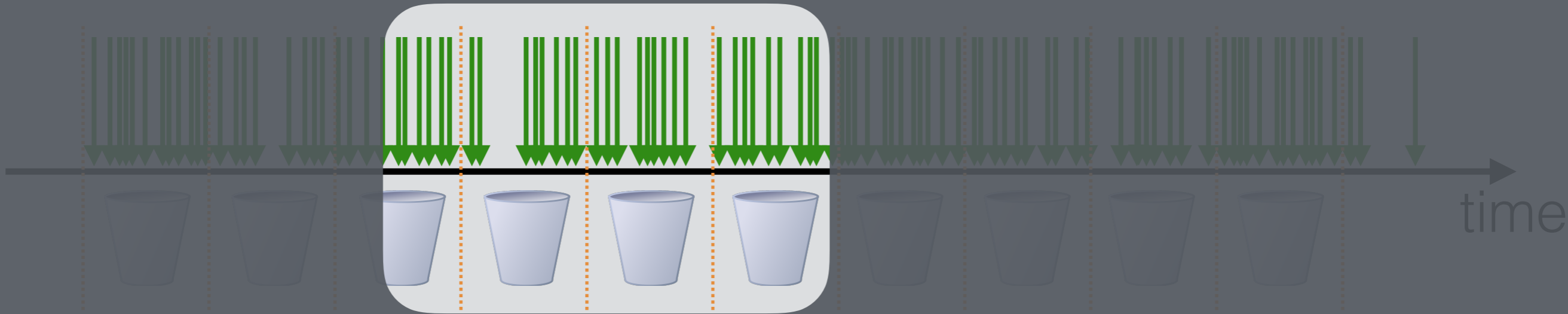

10s





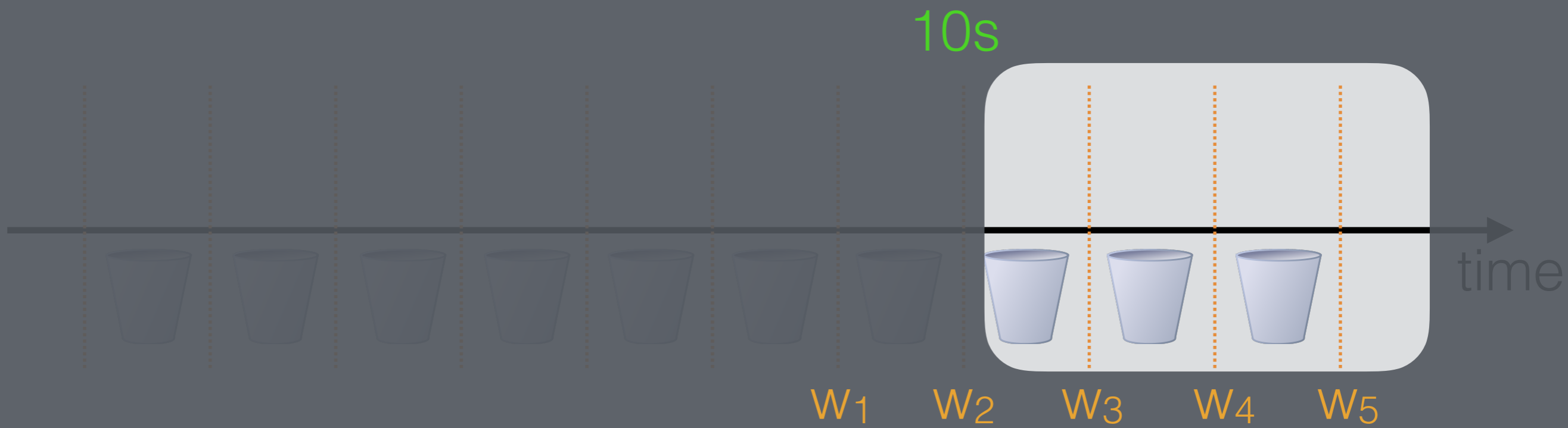

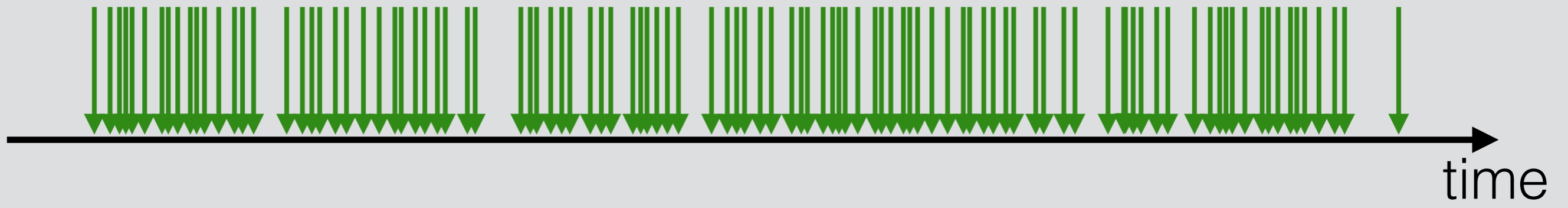

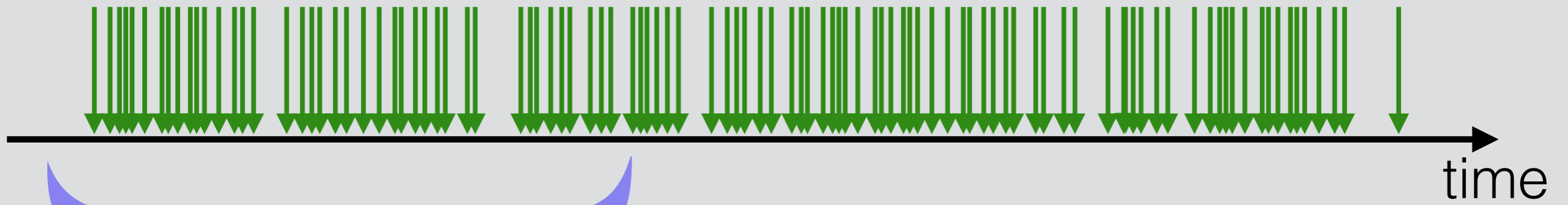

0	0	1	2	2	1	3	9	4	6	5	2
---	---	---	---	---	---	---	---	---	---	---	---

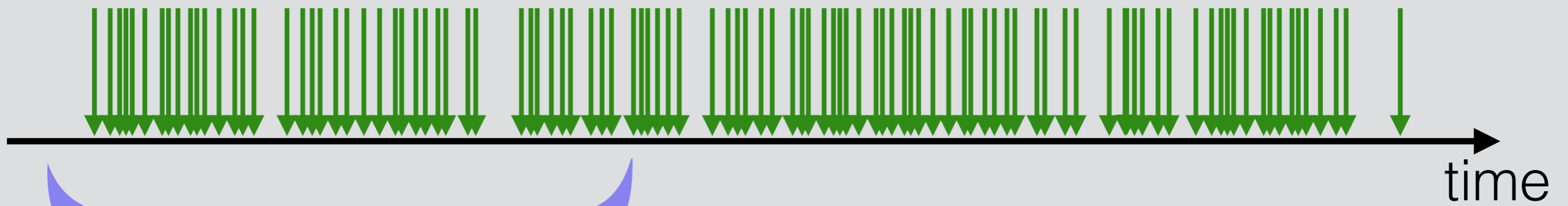

0	0	1	2	2	1	3	9	4	6	5	2
---	---	---	---	---	---	---	---	---	---	---	---

⊥	⊥	⊥	⊥	⊥	⊥	⊥	⊥	⊥	⊥	⊥	⊥
---	---	---	---	---	---	---	---	---	---	---	---

0	0	1	2	2	3	3	3	4	5	5	5
---	---	---	---	---	---	---	---	---	---	---	---

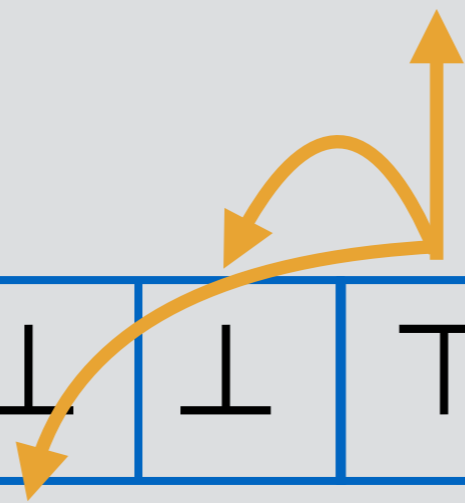

# Example: Amazon



# Example: Amazon



Does the star average of any product increase significantly?

```

in string pid
in double stars
time in int timestamp

out bool low_freq <string prod>
  inv: pid
  ter: low_freq
  := arr_freq(prod)[0, 0] < 20

out int time_p <string prod>
  inv: pid
  ext: pid = prod
  ter: low_freq
  := timestamp

out int arr_freq <string prod>
  inv: pid
  ext: pid = prod
  ter: low_freq
  := time_p(prod)
     [slide, 1day, cnt, 0]

```

```

out double star_avg <string prod>
  inv: pid
  ext: pid = prod
  ter: low_freq
  := stars[slide, 1day, avg, 0.0]

out double star_avg_d <string prod>
  inv: pid
  ext: pid = prod
  ter: low_freq
  := (
    star_avg(prod)[0, 0.0]
    - star_avg(prod)[-1, 0.0]
  ) / (
    time_p(prod)[0, 0]
    - time_p(prod)[-1, 0]
  )

trigger any(star_avg_d > 2.5)

```

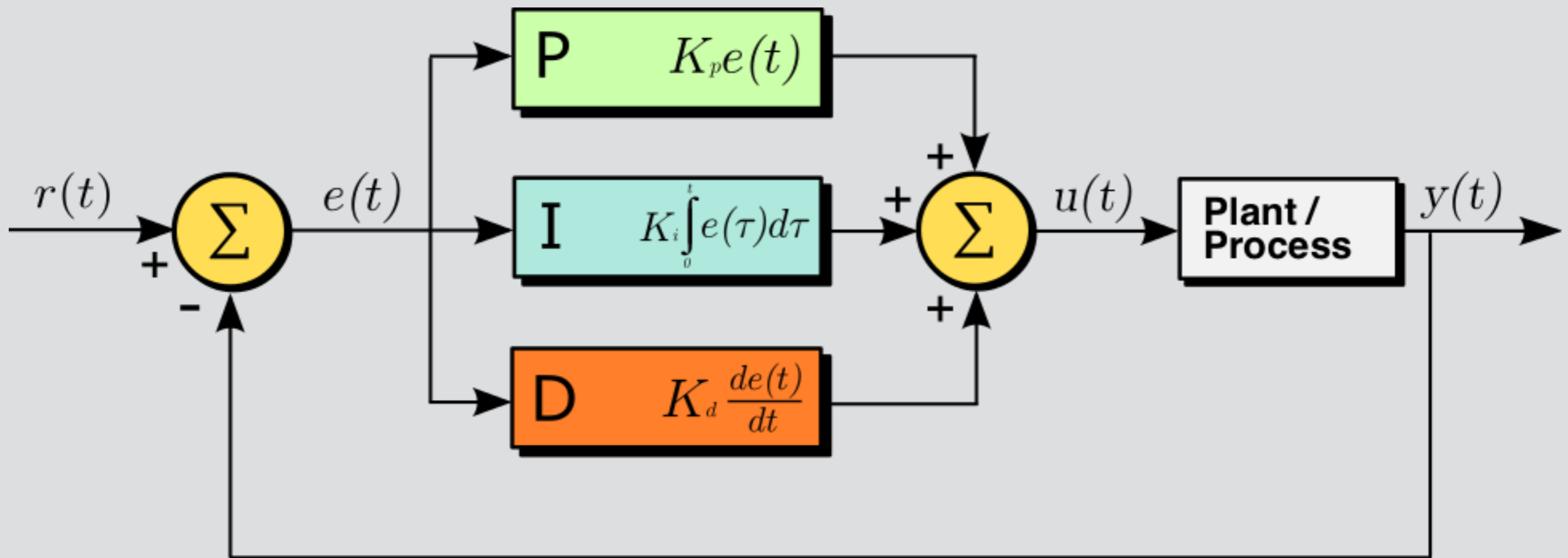



```
in double sensor
time in double timestamp
in double ref
```

```
out double error
    := acc_sensor - acc_ref
```

```
out double acc_sensor
    := sensor[slide, 1min, integral, 0]
```

```
trigger any(error > 5)
```

```
out double acc_ref
    := ref[slide, 1min, integral, 0]
```

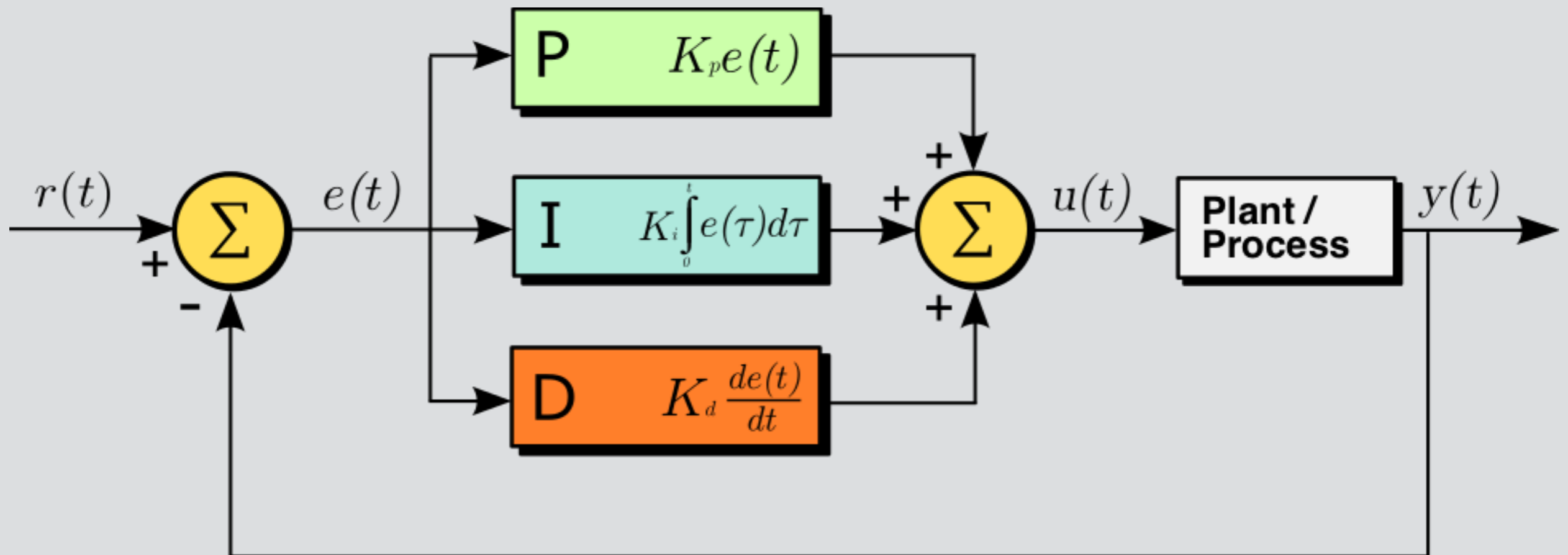

```
in double sensor
time in double timestamp
in double ref
```

```
out double acc_sensor
:= sensor[slide, 1min, integral, 0]
```

```
out double acc_ref
:= ref[slide, 1min, integral, 0]
```

```
out double error
:= acc_sensor - acc_ref
```

```
trigger any(error > 5)
```

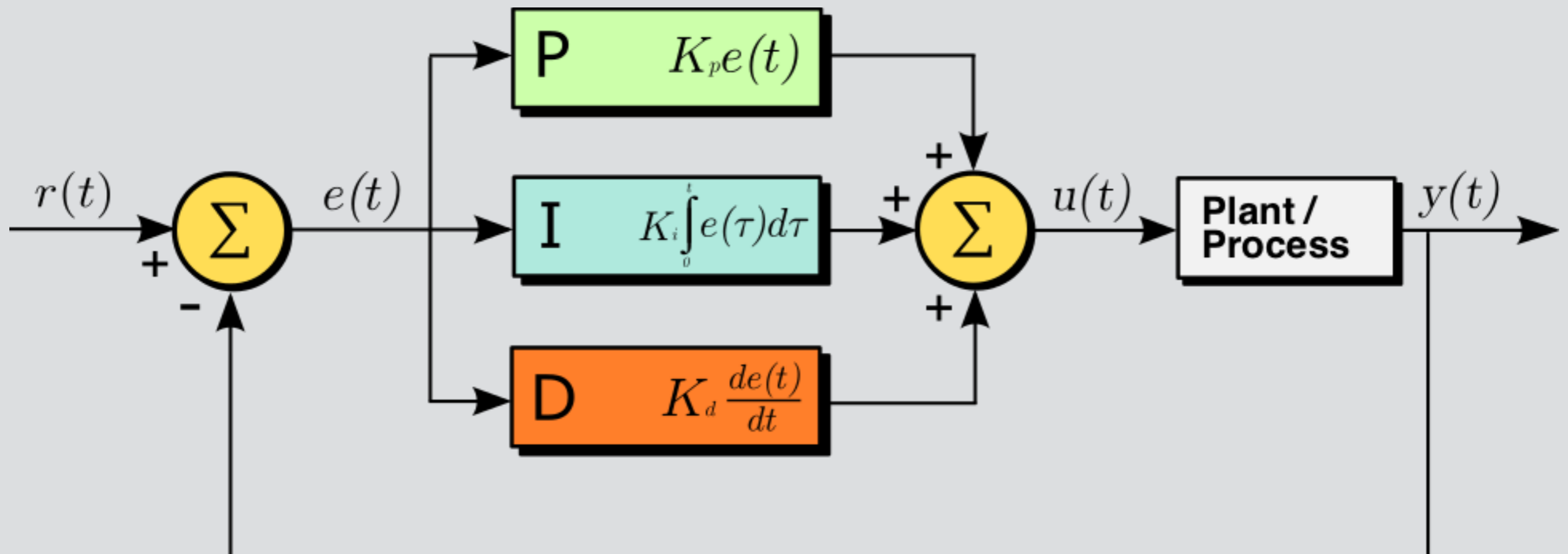

# Time and Space

Time:  $O(\text{freq} * \text{window size} * O(\circ))$

# Time and Space

Time:  $O(\text{freq} * \text{window size} * O(\circ))$

no



$O(\text{freq} * \text{window size})$



$O\left(\frac{\text{window size}}{\text{bucket size}}\right)$

# Time and Space

Time:  $O(\text{freq} * \text{window size} * O(\circ))$

no



$O(\text{freq} * \text{window size})$

$O\left(\frac{\text{window size}}{\text{bucket size}}\right)$



Norbert Aepli, Switzerland

```

in double sensor
time in double timestamp
in double ref

```

```

out double acc_sensor
:= sensor[slide, 1min,
integral, 0]

```

```

out double acc_ref
:= ref[slide, 1min,
integral, 0]

```

