

Embedded Systems 2010/2011 – Assignment Sheet 6

Due: Tuesday, 7th December 2010, *before* the lecture (i.e., 10:10)

Please indicate your **name**, **matr. number**, **email address**, and which **tutorial** you are planning to attend on your submission. We encourage you to collaborate in **groups** of up to **three** students. Only one submission per group is necessary. However, in the tutorials every group member must be capable to present each solution.

Exercise 1: Synchronous Data Flow – Part 1

(25 pts.)

Consider the SDF network given in Figure 1, where the initial number of items (or the initial delay) of the buffer between *O* and *H* is 2.

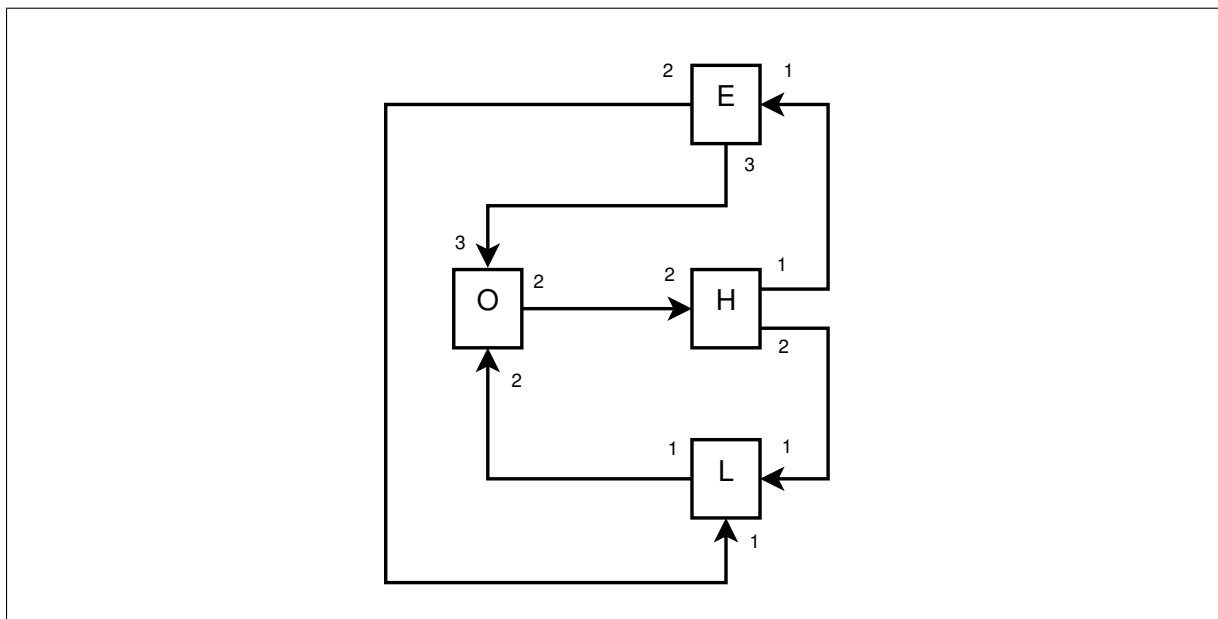

Figure 1: SDF network for Exercise 1.

- (a) Write down the topology matrix according to Lee/Messerschmitt. (5 pts.)
- (b) Use the matrix to deduce the relative execution rates.
 Write down your intermediate steps! (12 pts.)
- (c) Determine a periodic schedule. (8 pts.)

Exercise 2: Synchronous Data Flow – Part 2

(25 pts.)

Consider the SDF network given in Figure 2, where the initial number of items (or the initial delay) of the buffer between B and A is 4.

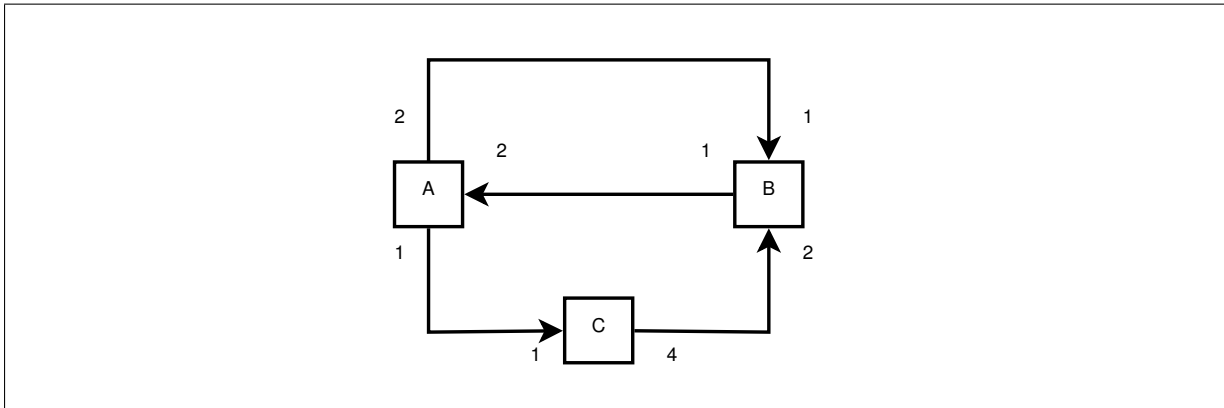

Figure 2: SDF network for Exercise 2.

- (a) Write down the topology matrix according to Lee/Messerschmitt. (5 pts.)
- (b) Use the matrix to deduce the relative execution rates.
Write down your intermediate steps! (12 pts.)
- (c) Determine a periodic schedule. (8 pts.)