

# Infinite Games

Deadline: 22 Oct. 2013

*Note:* All definitions and notations that you need and should use can be found in the lecture notes available on our course web page.

## Exercise 1.1 - Recap ( $\frac{1}{2} + \frac{1}{2} + \frac{1}{2} + \frac{1}{2}$ Points)

This exercise should help you to recapitulate some basics that we will use during the lecture. Therefore, have a look at the first chapter of the script where you can find the corresponding notions and definitions.

Let  $\Sigma = \{a, b, c\}$  be an alphabet. Define the following languages using  $\omega$ -regular expressions.

- $L_1 = \{w \in \Sigma^\omega \mid \text{there are infinitely many } a \text{ in } w \text{ but only finitely many } b\}$
- $L_2 = \{w \in \Sigma^\omega \mid \text{every } a \text{ in } w \text{ is eventually followed by a } b \text{ unless there are infinitely many } c \text{ in } w\}$
- $L_3 = \{w \in \Sigma^\omega \mid w \text{ does not contain infinitely many } c \text{ followed by an } a \text{ or a } b\}$
- $L_4 = \{w \in \Sigma^\omega \mid \text{between every pair of } a \text{ in } w \text{ there are at least two } b \text{ and at most one } c\}$

## Exercise 1.2 - Games (2 + 1 + 2 + 1 Points)

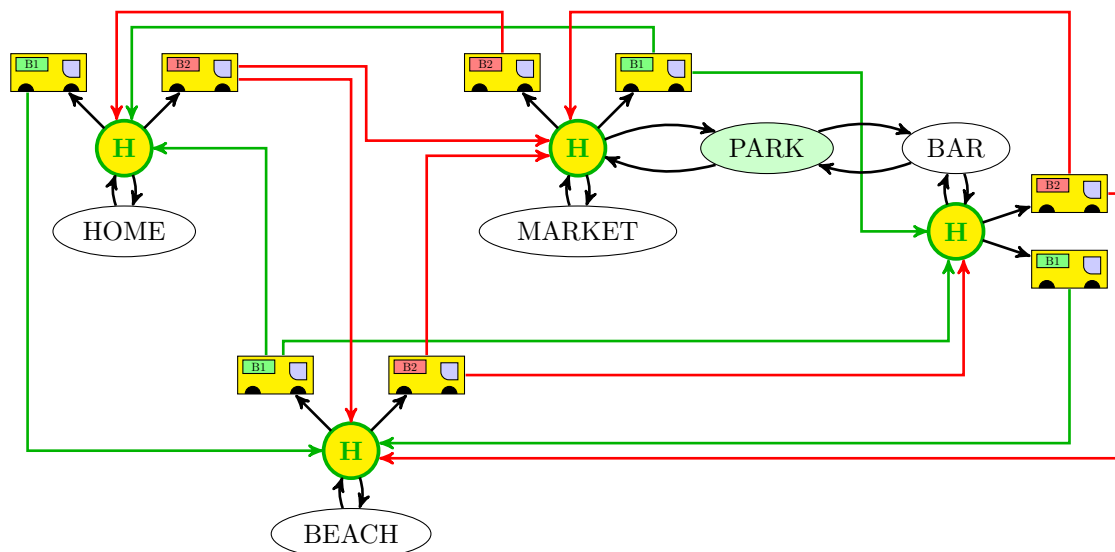

Andrew had a nice day at the beach and now wants to go home. As he has a bus ticket for the whole day he decides to travel by bus and therefore has a look at the bus plan above. Unfortunately, he forgot his watch and the buses drive to different locations at different times here. Consequently, he cannot exactly determine the destination a specific bus drives to. Further, it may be useful to know that Andrew is very forgetful, meaning he cannot remember the directions he already has taken<sup>1</sup>.

- Can you help Andrew by providing a strategy bringing him home? Andrew may use the opportunity to take a shortcut by walking through the park. Describe your solution formally and argue why it is correct.
- After Andrew arrived at home he decides to meet some friends in the bar. How many possibilities (strategies) can he use to get there? How do you get to this answer?
- Andrew wants to buy some presents for his friends at the market before he arrives at the bar. Is this possible such that his friends do not see him at the bar before? Argue formally.

<sup>1</sup>or even more precisely: he only understands positional strategies

- d) Formalize the above problems as games. More precisely, give a formal representation the corresponding winning conditions. You can assume the arena to be given by  $\mathcal{A}$ . You also do not have to solve the games again.

(Hint: It may be useful to consider the bus plan as a directed graph with round and rectangular vertices.)

### Exercise 1.3 - Games

(3 + 2 + 2 Points)

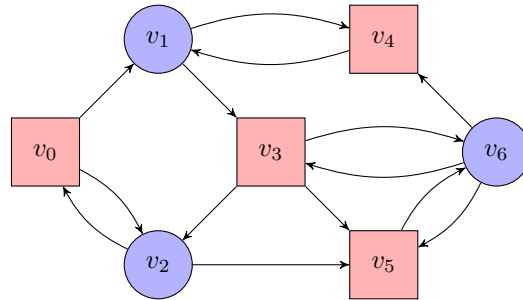

Consider the game  $\mathcal{G} = (\mathcal{A}, \text{Win})$  with the arena  $\mathcal{A} = (V, V_0, V_1, E)$  depicted above and the winning condition  $\text{Win}$  defined as  $\text{Win} = \{\rho \in \text{Plays}(\mathcal{A}) \mid \text{Occ}(\rho) = V\}$ . A play is winning for Player 0 in this game iff all vertices are visited during the play.

- Give at least one winning strategy from some vertex for each player. Argue why they are winning.
- Determine the winning regions of the game. You do not have to give a justification.
- Is the game positionally determined? Argue formally.

### Exercise 1.4 - Challenge

(2 Bonus Points)

Prove or disprove: If player  $i$  has a positional winning strategy from each vertex  $v \in W_i(\mathcal{G})$  in an arbitrary game  $\mathcal{G}$  then player  $i$  has a uniform positional winning strategy.